

BUSHES

	<i>Página</i>
207 DIE BUSHES DIN 9845-A HEADLESS	II-17
208 DIE BUSHES DIN 9845-B HEADED	II-18
209 GUIDED BUSHES DIN 9845-C	II-19
217 SHAPED DIE BUSHES ISO 8977 HEADED	II-22
224 LIGHT DUTY BALL LOCK	II-29
215 MATRIXES WITH START BORE ISO 8977A	II-20
216 MATRIXES WITH START BORE ISO 8977B	II-21

PUNCHES

214 BOTTLE-NECK PUNCH "BN"	II-13
225 CYLINDRICAL HEAD PUNCH RETAINERS " HHR "	II-27
203 PUNCH CYLINDRICAL HEAD TYPE "A" ISO 8020/8021	II- 7
211 PUNCH CYL. HEAD TYPE "E" W/Spring Loaded Ej. Pin ISO 8020/8021	II-10
201 PUNCH TYPE "D" DIN 9861 COUNTERSUNK HEAD	II- 1-2-3-4-5
206 SPECIAL SHAPES PRECISION PUNCHES	II-16
205 SQUARED & RECTANGULAR PUNCHES TYPE "DA"	II-15
204 STEPPED PUNCH CYLINDRICAL HEAD TYPE "B" ISO 8020/8021	II- 8
210 STEPPED (SHAPED) PUNCH CYL. HEAD TYPE "CA" ISO 8020/8021	II- 9
212 STEPPED PUNCH CYL. HEAD TYPE "F" W/Spring Loaded Ej. Pin ISO 8020	II-11
213 STEPPED (SHAPED) PUNCH CYLINDRICAL HEAD TYPE "G" With Spring Loaded Ejector Pin ISO 8020	II-12
202 STEPPED PUNCH TYPE "C" DIN 9861 COUNTERSUNK HEAD	II- 6
220 HEAVY DUTY REGULAR PUNCHES	II-23
221 LIGHT DUTY REGULAR PUNCHES	II-24
222 HEAVY DUTY BALL LOCK PUNCHES WITH EJECTOR	II-25
223 LIGHT DUTY BALL LOCK PUNCHES WITH EJECTOR	II-26
218 PRECISION PUNCHES FORM "AF" AND "BF"	II-14
226 SINGLE BALL LOCK CYLINDRICAL HEAD PUNCH RETAINERS " HHS "	II-28



PUNZON DE CORTE CILINDRICO CABEZA CONICA FORMA "D" DIN 9861 ISO 6752w PUNCH WITH COUNTERSUNK HEAD FORM "D" DIN 9861 ISO 6752

MATERIAL : Ac.Carbono WS , 12% Cromo HWS y Ac. Rapido HSS.
FABRICACION : Templado, revenido y rectificado totalmente, excepto Ac.Carbono.
VERSION : Hardened, tempered and fully fine ground finished, excepting WS.
 Cabeza estampada en caliente.
 Head hot tempered and annealed.
 Los punzones en 12% Cromo resisten temperaturas de hasta 520° C.
 Punches in HWS are heat resistant up to 520 ° C.

DUREZAS : **D1:** 60-62 HRC.(WS y HWS)
HARDNESS : 62-64 HRC.(HSS)
 Cabeza: 45±5 HRC.
 Head:

d1 (h6)	d2 (±0,2)	h (+0,2)	L + 0,5
0.3	0.9	0.72	71 - 80 - 100
0.35	0.9	0.68	71 - 80 - 100
0.4	0.9	0.63	71 - 80 - 100
0.45	0.9	0.59	71 - 80 - 100
0.5	0.9	0.55	71 - 80 - 100
0.55	1.0	0.59	71 - 80 - 100
0.6	1.1	0.63	71 - 80 - 100
0.65	1.2	0.68	71 - 80 - 100
0,7	1.3	0.72	71 - 80 - 100
0,75	1.3	0.68	71 - 80 - 100
0,8	1.4	0.92	71 - 80 - 100
0,85	1.4	0.88	71 - 80 - 100
0,9	1.6	1.01	71 - 80 - 100
0,95	1.6	0.96	71 - 80 - 100
1,0	1.8	1.19	71 - 80 - 100
1,05	1.8	1.15	71 - 80 - 100
1,1	1.8	1.11	71 - 80 - 100
1,15	1.8	1.06	71 - 80 - 100
1,20	2.0	1.19	71 - 80 - 100
1,25	2.0	1.15	71 - 80 - 100
1,3	2.0	1.11	71 - 80 - 100
1,35	2.0	1.06	71 - 80 - 100
1,4	2.2	1.19	71 - 80 - 100
1,45	2.2	1.15	71 - 80 - 100
1,5	2.2	1.11	71 - 80 - 100
1,55	2.2	1.06	71 - 80 - 100
1,6	2.5	1.28	71 - 80 - 100
1,65	2.5	1.24	71 - 80 - 100
1,7	2.5	1.19	71 - 80 - 100
1,75	2.5	1.15	71 - 80 - 100
1,8	2.8	1.37	71 - 80 - 100
1,85	2.8	1.32	71 - 80 - 100
1,9	2.8	1.28	71 - 80 - 100
1,95	2.8	1.24	71 - 80 - 100
2,0	3.0	1.37	71 - 80 - 100
2,05	3.0	1.32	71 - 80 - 100
2,10	3.2	1.45	71 - 80 - 100
2,15	3.2	1.41	71 - 80 - 100
2,2	3.2	1.37	71 - 80 - 100
2,25	3.2	1.32	71 - 80 - 100
2,3	3.5	1.54	71 - 80 - 100
2,35	3.5	1.50	71 - 80 - 100

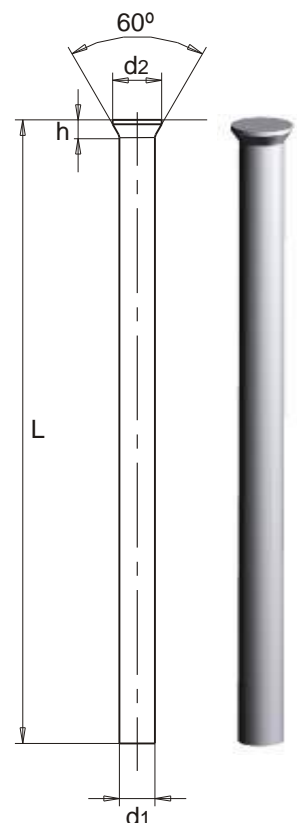

FORMA DE PEDIDO: ORDER FORM: Material,d1 x L.
L=130 DISPONIBLE SOLO EN ACERO RÁPIDO L=130 AVAILABLE ONLY IN HSS

**PUNZON DE CORTE CILINDRICO CABEZA CONICA FORMA "D" DIN 9861 ISO 6752
(CONTINUACION)**
PUNCH WITH COUNTERSUNK HEAD FORM "D" DIN 9861 ISO 6752 (CONT.)

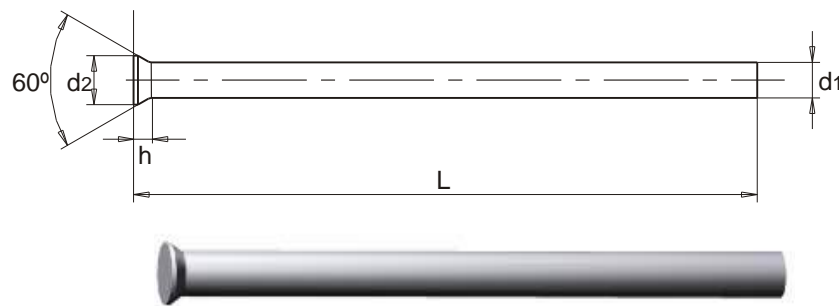

d1 (h6)	d2 ($\pm 0,2$)	h (+0,2)	L + $\begin{smallmatrix} 0,5 \\ 0 \end{smallmatrix}$
3.05	4.5	1.76	71 - 80 - 100
3.10	4.5	1.71	71 - 80 - 100
3.15	4.5	1.67	71 - 80 - 100
3.2	4.5	1.63	71 - 80 - 100
3.25	4.5	1.58	71 - 80 - 100
3.3	4.5	1.54	71 - 80 - 100
3.35	4.5	1.50	71 - 80 - 100
3.4	4.5	1.45	71 - 80 - 100
3.45	4.5	1.41	71 - 80 - 100
3.5	5.0	1.80	71 - 80 - 100
3.55	5.0	1.76	71 - 80 - 100
3.6	5.0	1.71	71 - 80 - 100
3.65	5.0	1.67	71 - 80 - 100
3.7	5.0	1.63	71 - 80 - 100
3.75	5.0	1.58	71 - 80 - 100
3.8	5.0	1.54	71 - 80 - 100
3.85	5.0	1.50	71 - 80 - 100
3.9	5.0	1.45	71 - 80 - 100
3.95	5.0	1.41	71 - 80 - 100
4.0	5.5	1.80	71 - 80 - 100 - 130
4.05	5.5	1.76	71 - 80 - 100
4.10	5.5	1.71	71 - 80 - 100
4.15	5.5	1.67	71 - 80 - 100
4.2	5.5	1.63	71 - 80 - 100
4.25	5.5	1.58	71 - 80 - 100
4.3	5.5	1.54	71 - 80 - 100
4.35	5.5	1.50	71 - 80 - 100
4.4	5.5	1.45	71 - 80 - 100
4.45	5.5	1.41	71 - 80 - 100
4.5	6.0	1.80	71 - 80 - 100
4.55	6.0	1.76	71 - 80 - 100
4.6	6.0	1.71	71 - 80 - 100
4.65	6.0	1.67	71 - 80 - 100
4.7	6.0	1.63	71 - 80 - 100
4.75	6.0	1.58	71 - 80 - 100
4.8	6.0	1.54	71 - 80 - 100
4.85	6.0	1.50	71 - 80 - 100
4.9	6.0	1.45	71 - 80 - 100
4.95	6.0	1.41	71 - 80 - 100
5.0	6.5	1.80	71 - 80 - 100 - 130

FORMA DE PEDIDO: ORDER FORM: Material, d1 x L.
L=130 DISPONIBLE SOLO EN ACERO RÁPIDO L=130 AVAILABLE ONLY IN HSS

**PUNZON DE CORTE CILINDRICO CABEZA CONICA FORMA "D" DIN 9861 ISO 6752
(CONTINUACION)**
PUNCH WITH COUNTERSUNK HEAD FORM "D" DIN 9861 ISO 6752 (CONT.)

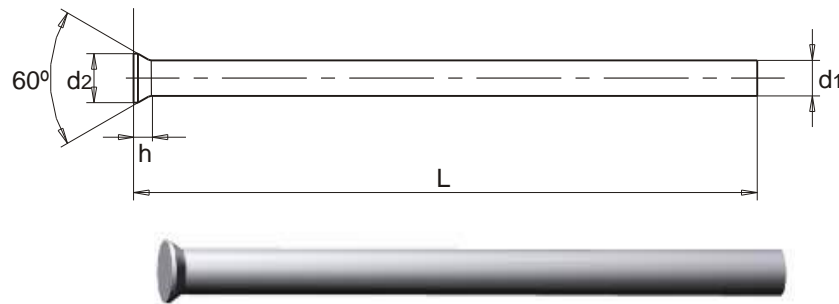

d1 (h6)	d2 ($\pm 0,2$)	h (+0,2)	L $+0,5$ 0
5.05	6.5	1.76	71 - 80 - 100
5.1	6.5	1.71	71 - 80 - 100
5.15	6.5	1.67	71 - 80 - 100
5.2	6.5	1.63	71 - 80 - 100
5.3	6.5	1.54	71 - 80 - 100
5.4	6.5	1.45	71 - 80 - 100
5.45	6.5	1.41	71 - 80 - 100
5.5	7.0	1.80	71 - 80 - 100
5.6	7.0	1.71	71 - 80 - 100
5.7	7.0	1.63	71 - 80 - 100
5.75	7.0	1.58	71 - 80 - 100
5.8	7.0	1.54	71 - 80 - 100
5.9	7.0	1.45	71 - 80 - 100
6.0	8.0	2.23	71 - 80 - 100 - 130
6.05	8.0	2.19	71 - 80 - 100
6.1	8.0	2.15	71 - 80 - 100
6.2	8.0	2.06	71 - 80 - 100
6.3	8.0	1.97	71 - 80 - 100
6.4	8.0	1.89	71 - 80 - 100
6.5	9.0	3.17	71 - 80 - 100
6.6	9.0	3.08	71 - 80 - 100
6.7	9.0	2.99	71 - 80 - 100
6.8	9.0	2.91	71 - 80 - 100
6.9	9.0	2.82	71 - 80 - 100
7.0	9.0	2.73	71 - 80 - 100 - 130
7.1	9.0	2.65	71 - 80 - 100
7.2	9.0	2.56	71 - 80 - 100
7.25	9.0	2.52	71 - 80 - 100
7.3	9.0	2.47	71 - 80 - 100
7.4	9.0	2.39	71 - 80 - 100
7.5	10.0	3.17	71 - 80 - 100
7.6	10.0	3.08	71 - 80 - 100
7.7	10.0	2.99	71 - 80 - 100
7.8	10.0	2.91	71 - 80 - 100
7.9	10.0	2.82	71 - 80 - 100
8.0	10.0	2.73	71 - 80 - 100 - 130
8.1	10.0	2.65	71 - 80 - 100
8.2	10.0	2.56	71 - 80 - 100
8.3	10.0	2.47	71 - 80 - 100
8.4	10.0	2.39	71 - 80 - 100

FORMA DE PEDIDO: ORDER FORM: Material, d1 x L.
L=130 DISPONIBLE SOLO EN ACERO RÁPIDO L=130 AVAILABLE ONLY IN HSS

PUNZON DE CORTE CILINDRICO CABEZA CONICA FORMA "D" DIN 9861 ISO 6752 (CONTINUACION)
PUNCH WITH COUNTERSUNK HEAD FORM "D" DIN 9861 ISO 6752 (CONT.)

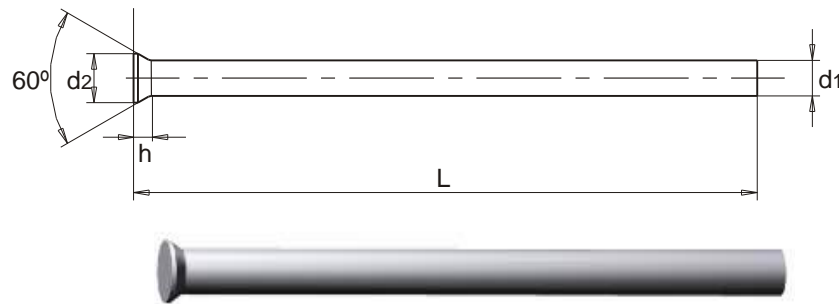

d1 (h6)	d2 (+0,2)	h (+0,2)	L + 0,5
8.5	11.0	3.17	71 - 80 - 100
8.6	11.0	3.08	71 - 80 - 100
8.7	11.0	2.99	71 - 80 - 100
8.8	11.0	2.91	71 - 80 - 100
8.9	11.0	2.82	71 - 80 - 100
9.0	11.0	2.73	71 - 80 - 100 - 130
9.05	11.0	2.69	71 - 80 - 100
9.1	11.0	2.65	71 - 80 - 100
9.2	11.0	2.56	71 - 80 - 100
9.3	11.0	2.47	71 - 80 - 100
9.4	11.0	2.39	71 - 80 - 100
9.5	12.0	3.17	71 - 80 - 100
9.6	12.0	3.08	71 - 80 - 100
9.7	12.0	2.99	71 - 80 - 100
9.8	12.0	2.91	71 - 80 - 100
9.9	12.0	2.82	71 - 80 - 100
10.0	12.0	2.73	71 - 80 - 100 - 130
10.1	12.0	2.65	71 - 80 - 100
10.2	12.0	2.56	71 - 80 - 100
10.3	12.0	2.47	71 - 80 - 100
10.4	12.0	2.39	71 - 80 - 100
10.5	13.0	3.17	71 - 80 - 100
10.6	13.0	3.08	71 - 80 - 100
10.7	13.0	2.99	71 - 80 - 100
10.8	13.0	2.91	71 - 80 - 100
10.9	13.0	2.82	71 - 80 - 100
11.0	13.0	2.73	71 - 80 - 100 - 130
11.1	13.0	2.65	71 - 80 - 100
11.2	13.0	2.56	71 - 80 - 100
11.3	13.0	2.47	71 - 80 - 100
11.4	13.0	2.39	71 - 80 - 100
11.5	14.0	3.17	71 - 80 - 100
11.6	14.0	3.08	71 - 80 - 100
11.7	14.0	2.99	71 - 80 - 100
11.8	14.0	2.91	71 - 80 - 100

FORMA DE PEDIDO: ORDER FORM: Material, d1 x L.
L=130 DISPONIBLE SOLO EN ACERO RÁPIDO L=130 AVAILABLE ONLY IN HSS

**PUNZON DE CORTE CILINDRICO CABEZA CONICA FORMA "D" DIN 9861 ISO 6752
(CONTINUACION)**
PUNCH WITH COUNTERSUNK HEAD FORM "D" DIN 9861 ISO 6752 (CONT.)

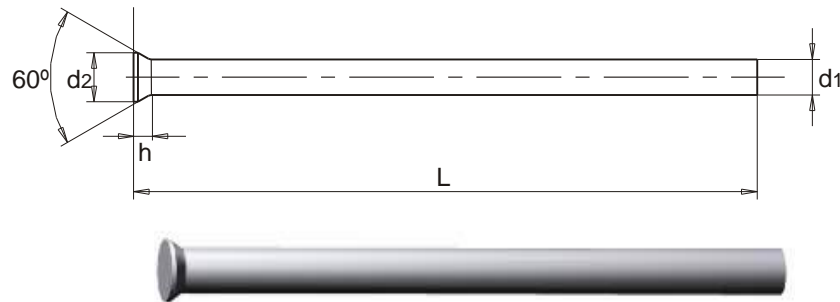

d1 (h6)	d2 ($\pm 0,2$)	h (+0,2)	L $\pm 0,5$
11.9	14.0	2.82	71 - 80 - 100
12.0	14.0	2.73	71 - 80 - 100 - 130
12.1	14.0	2.65	71 - 80 - 100
12.2	14.0	2.56	71 - 80 - 100
12.3	14.0	2.47	71 - 80 - 100
12.4	14.0	2.39	71 - 80 - 100
12.5	15.0	3.17	71 - 80 - 100
12.6	15.0	3.08	71 - 80 - 100
12.7	15.0	2.99	71 - 80 - 100
12.8	15.0	2.91	71 - 80 - 100
12.9	15.0	2.82	71 - 80 - 100
13.0	15.0	2.73	71 - 80 - 100
13.5	16.0	3.67	71 - 80 - 100
14.0	16.0	3.23	71 - 80 - 100
14.5	17.0	3.67	71 - 80 - 100
15.0	17.0	3.23	71 - 80 - 100
15.5	18.0	3.67	71 - 80 - 100
16.0	18.0	3.23	71 - 80 - 100
16.5	19.0	3.67	71 - 80 - 100
17.0	19.0	3.23	71 - 80 - 100
17.5	20.0	3.67	71 - 80 - 100
18.0	20.0	3.23	71 - 80 - 100
18.5	21.0	3.67	71 - 80 - 100
19.0	21.0	3.23	71 - 80 - 100
19.5	22.0	3.67	71 - 80 - 100
20.0	22.0	3.23	71 - 80 - 100

FORMA DE PEDIDO: ORDER FORM: Material, d1 x L.
L=130 DISPONIBLE SOLO EN ACERO RÁPIDO L=130 AVAILABLE ONLY IN HSS
TAMBIEN DISPONIBLES TODOS LOS DIAMETROS ,25 Y ,75 mm.
ALSO AVAILABLE ALL DIAMETERS ,25 AND ,75 mm.

PUNZON DE CORTE MECHADO CABEZA CONICA FORMA "C" DIN 9861 ISO 9181
STEPPED PUNCH WITH COUNTERSUNK HEAD FORM "C" DIN 9861 ISO 9181

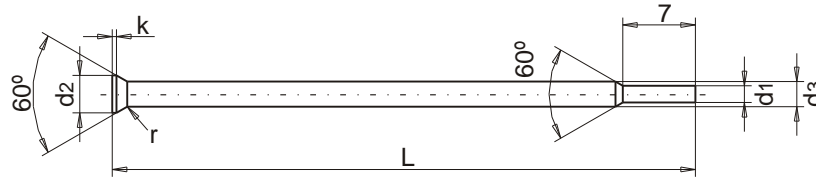

- MATERIAL:** 12% Cromo HWS y Ac. Rapido HSS.
FABRICACION: Templado, revenido y rectificado totalmente.
VERSION: Hardened, tempered and fully fine ground finished.
 Cabeza estampada en caliente.
 Los punzones en 12% Cromo resisten temperaturas de hasta 520 ° C.
 Head hot tempered and annealed. Punches in HWS are heat resistant up to 520° C.
- DUREZAS:** d1 y d3: 60-62 HRC.(HWS)
HARDNESS: 62-64 HRC.(HSS)
 Cabeza: 45±5 HRC.
 Head:

d1 (h6)	d3 (h6)	d2 (-0,2)	K (+0,2)	L + 0,5
0,5 a 0,95	2	3	0.5	71
1,0 a 1,45	2	3	0.5	71
1.5	2-3	3,0 - 4,5	0.5	71
1,55 a 2,25	3	4.5	0.5	71
2,3 a 2,95	3	4.5	0.5	71

FORMA DE PEDIDO: Material - d1 x d3 x L.

ORDER FORM : Material - d1 x d3 x L.

PUNZON DE CORTE CABEZA CILINDRICA FORMA "A" ISO 8020-8021

PUNCH WITH CYLINDRICAL HEAD FORM "A" ISO 8020-8021

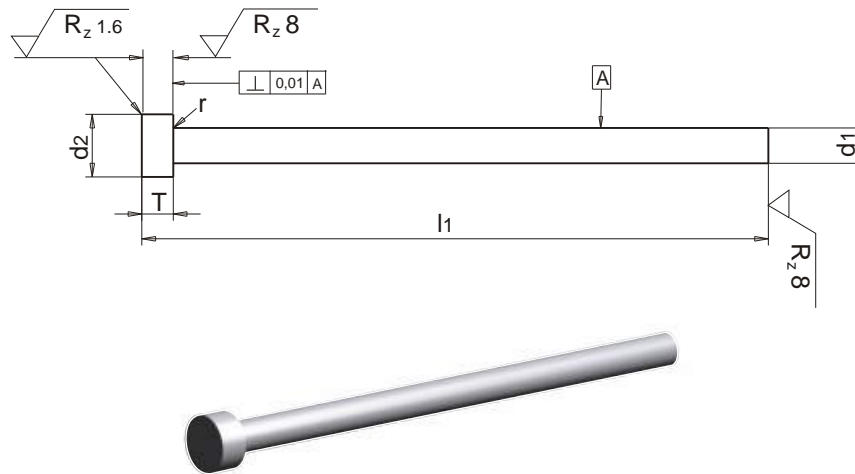

MATERIAL: 12% Cromo HWS y Ac. Rapido HSS.

FABRICACION: Templado, revenido y rectificado. Cabeza estampada en caliente.
Los punzones en 12% Cromo resisten temperaturas de hasta 520 ° C.

VERSION: Hardened, tempered and fully fine ground finished. Head hot tempered and annealed.
Punches in HWS are heat resistant up to 520° C.

DUREZAS:
HARDNESS :

HWS: Caña / Shaft = HRC 62±2
Cabeza / Head = HRC 50±5

HSS: Caña / Shaft = HRC 64±2
Cabeza / Head = HRC 50±5

d1 (m5)	d2 (+0-0,15)	T (+0.2 +0.1)	r (+0.1-0)	l1 (+0.5+0.2)
3	5	3	0.3	63-71-80
4	6	3	0.3	63-71-80-90-100
5	8	5	0.3	63-71-80-90-100
6	9	5	0.3	63-71-80-90-100
8	11	5	0.3	63-71-80-90-100
10	13	5	0.3	63-71-80-90-100
13	16	5	0.4	63-71-80-90-100
16	19	5	0.4	63-71-80-90-100
20	24	5	0.4	63-71-80-90-100
25	29	5	0.4	63-71-80-90-100
32	36	5	0.4	80-90-100

OTRAS LONGITUDES BAJO DEMANDA. / OTHER LENGTHS UNDER REQUEST.

FORMA DE PEDIDO: A - HWS o HSS d1 x l1.

ORDER FORM : A - HWS or HSS d1 x l1.

PUNZON CABEZA CILINDRICA MECHADO FORMA "B" ISO 8020-8021 STEPPED PUNCH WITH CYLINDRICAL HEAD FORM "B" ISO 8020-8021

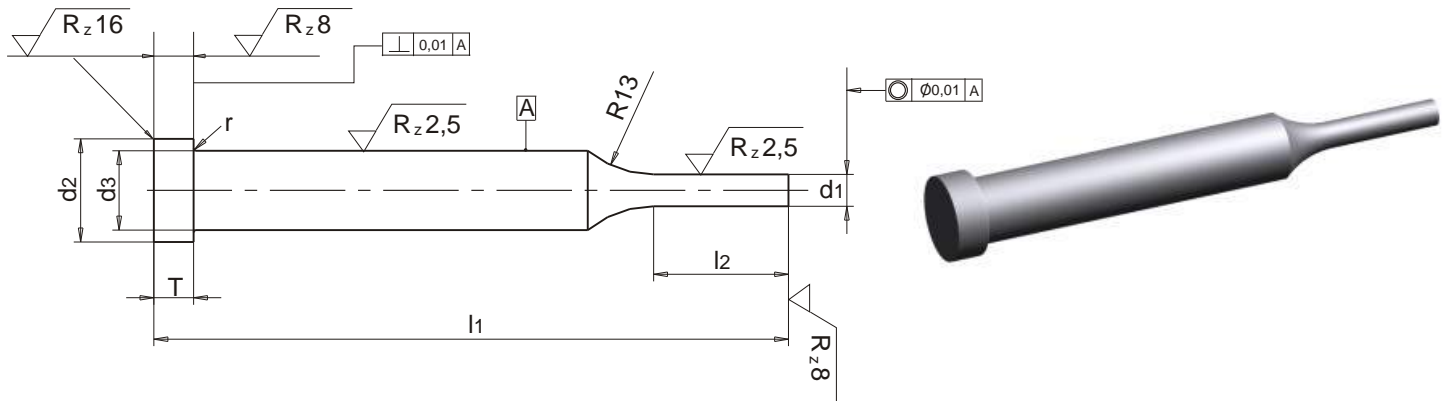

MATERIAL: 12% Cromo HWS y Ac. Rapido HSS.

FABRICACION: Templado, revenido y rectificado. Cabeza estampada en caliente.
Los punzones en 12% Cromo resisten temperaturas de hasta 520 ° C.

VERSION: Hardened, tempered and fully fine ground finished. Head hot tempered and annealed.
Punches in HWS are heat resistant up to 520° C.

DUREZAS: HWS: Caña / Shaft = HRC 62±2
Cabeza / Head = HRC 50±5

HARDNESS: HSS: Caña / Shaft = HRC 64±2
Cabeza / Head = HRC 50±5

d1 (j6)	Incr. d1	d2 (+0-0.15)	d3 (m5)	T (+0.2+0.1)	r (+0.1-0)	l2 (+0.5-0)	l1 (+0.5+0.2)
0,8 a 2,9	0.1	5	3	3	0.3	10	71-80
1,0 a 3,9	0.1	6	4	3	0.3	10	71-80
1,2 a 4,9	0.1	8	5	5	0.3	10	71-80
1,6 a 5,9	0.1	9	6	5	0.3	10	71-80-90-100
2,5 a 7,9	0.1	11	8	5	0.3	13	71-80-90-100
4,0 a 9,9	0.1	13	10	5	0.3	17	71-80-90-100
5,0 a 12,9	0.1	16	13	5	0.4	17	71-80-90-100
8,0 a 15,9	0.1	19	16	5	0.4	17	71-80-90-100
12,0 a 19,5	0.5	24	20	5	0.4	17	80-90-100
16,5 a 24,5	0.5	29	25	5	0.4	17	80-90-100

OTRAS LONGITUDES BAJO DEMANDA. / OTHER LENGTHS UNDER REQUEST.

FORMA DE PEDIDO: B - HWS o HSS d1 x d3 x l1.

ORDER FORM: B - HWS or HSS d1 x d3 x l1.

SUMINISTRABLE BAJO PEDIDO. / AVAILABLE UNDER REQUEST.

PUNZON DE CORTE CABEZA CILINDRICA MECHADO FORMA "CA" ISO 8020-8021
STEPPED PUNCH WITH CYLINDRICAL HEAD FORM "CA" ISO 8020-8021

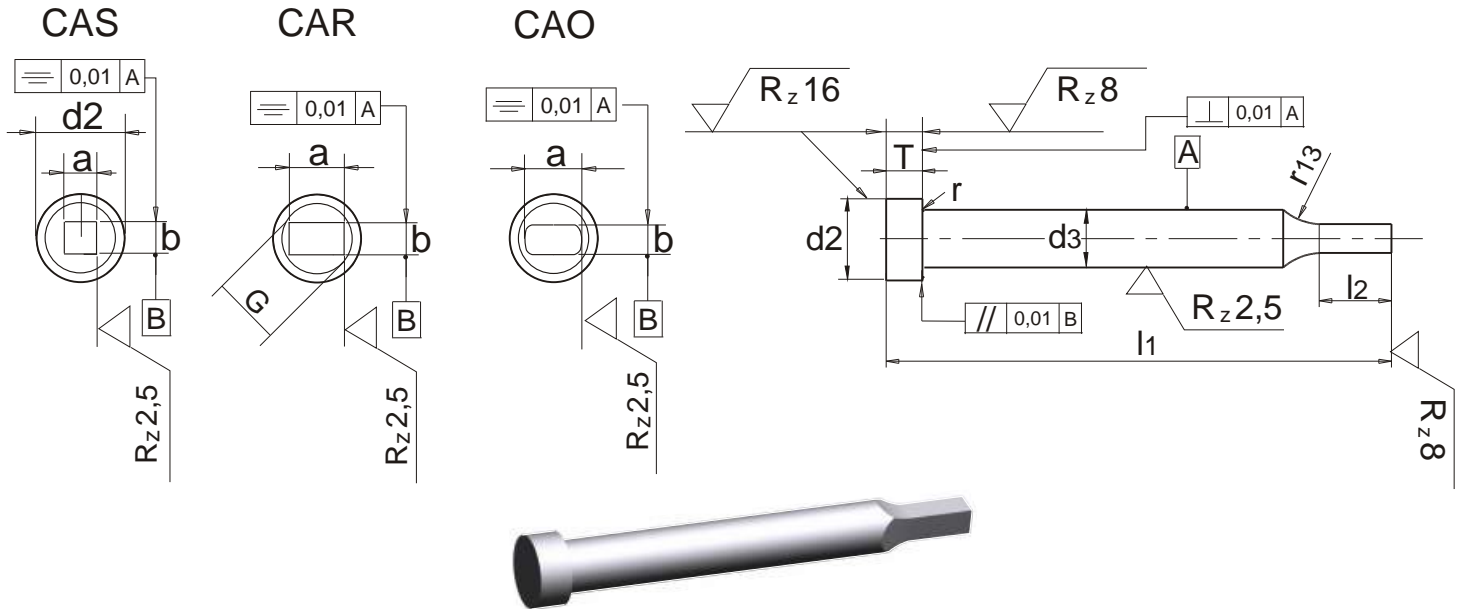

TIPOS / TYPES: **Tipo / Type CAS:** Mecha cuadrada. / Square stepped shaft
Tipo / Type CAR: Mecha rectangular. / Rectangular stepped shaft
Tipo / Type CAO: Mecha ovalada. / Oblong stepped shaft

CARACTERISTICAS / VERSION : Identicas a los punzones Tipo A.
 Same as punches Type A.

MATERIAL: 12% Cromo HWS y Ac. Rapido HSS.

DUREZAS: **HWS: Caña / Shaft** = HRC 62±2
Cabeza / Head = HRC 50±5
HARDNESS: **HSS: Caña / Shaft** = HRC 64±2
Cabeza / Head = HRC 50±5

a (+0.01) b (+0.01)	d2 (+0-0.15)	d3 (m5)	T (+0.2+0.1)	r (+0,1-0)	l2 (+0.5-0)	l1 (+0.5+0.2)
El que quiera el cliente. On customer request. G = max d3	6	4	3	0.3	Dimensiones preferidas.	71-80
	8	5	5	0.3		71-80
	9	6	5	0.3		71-80-90-100
	11	8	5	0.3	10 , 13 , 17.	71-80-90-100
	13	10	5	0.3	Otras longitudes disponibles bajo demanda.	71-80-90-100
	16	13	5	0.4		71-80-90-100
	19	16	5	0.4		71-80-90-100
	24	20	5	0.4	Other lengths under request.	80-90-100
	29	25	5	0.4		80-90-100

OTRAS LONGITUDES BAJO DEMANDA. / OTHER LENGTHS ON REQUEST.

TAMBIEN FABRICAMOS CASQUILLOS PARA ESTOS PUNZONES.

WE ALSO PRODUCE BUSHES FOR THESE PUNCHES.

FORMA DE PEDIDO / ORDER FORM: Material ,a x b x d2 x l2 x l1.

SUMINISTRABLE BAJO PEDIDO. / AVAILABLE UNDER REQUEST.

PUNZON CABEZA CILINDRICA FORMA "E" CON EXPULSOR INTERIOR, ISO 8020
PUNCH WITH CYLINDRICAL HEAD TYPE "E" WITH SPRING LOADED EJECTOR PIN, ISO 8020

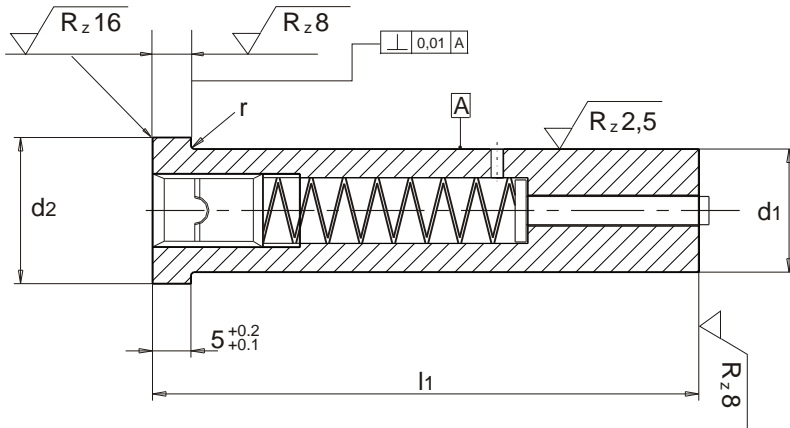

CARACTERISTICAS :

Templado, rectificado y lapeado. Cabeza estampada en caliente. Ensamblado con muelle espiral especial, tornillo deslizante y expulsor. El muelle que aloja al expulsor es ajustable gracias al tornillo que lleva alojado en su cabeza.

VERSION:

Hardened, tempered, shaft fine ground finished. Completely assembled with coil spring, pin bolt and ejector. Spring pressure of ejector can be adjusted at pin bolt on head.

MATERIAL:

Acero rápido / HSS.

DUREZAS:

Caña / Shaft = HRC 64±2

HARDNESS:

Cabeza / Head = HRC 50±5

d1 (m5)	d2 (+0-0,15)	r (+0,1-0)	l1 (+0,5+0,2)
6	9	0.3	71-80-90-100
8	11	0.3	71-80-90-100
10	13	0.3	71-80-90-100
13	16	0.4	71-80-90-100
16	19	0.4	71-80-90-100
20	24	0.4	80-90-100
25	29	0.4	80-90-100

SUMINISTRA BAJO DEMANDA.

AVAILABLE UNDER REQUEST

FORMA DE PEDIDO / ORDER FORM : E - HSS d1 x l1

PUNZON CABEZA CILINDRICA MECHADO FORMA "F" CON EXPULSOR INTERIOR, ISO 8020
STEPPED PUNCH WITH CYLINDRICAL HEAD TYPE "F" WITH SPRING LOADED EJECTOR PIN, ISO 8020

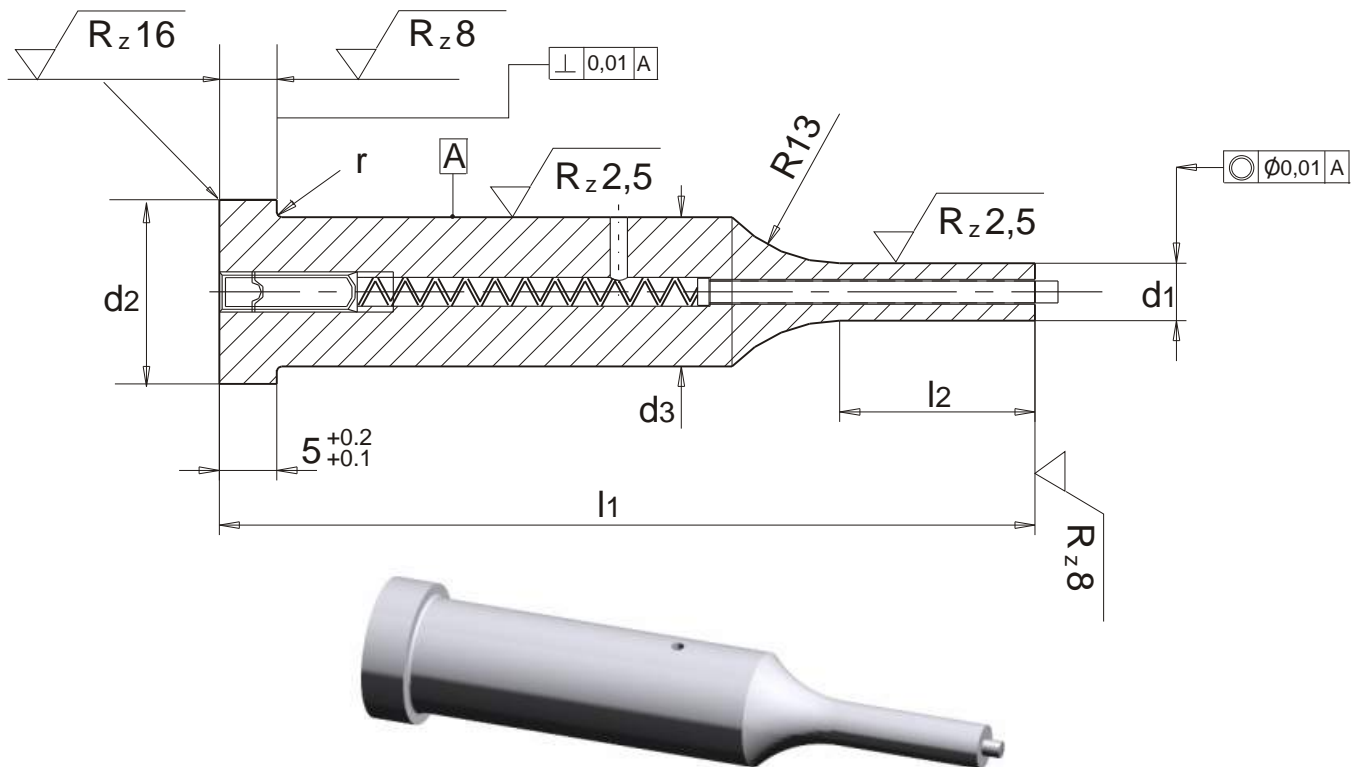
**CARACTERISTICAS :**

Templado, rectificado y lapeado. Cabeza estampada en caliente. Ensamblado con muelle espiral especial, tornillo deslizante y expulsor. El muelle que aloja al expulsor es ajustable gracias al tornillo que lleva alojado en su cabeza.

VERSION:

Hardened, tempered, shaft fine ground finished. Completely assembled with coil spring, pin bolt and ejector. Spring pressure of ejector can be adjusted at pin bolt on head.

MATERIAL:

Acero rápido / HSS.

DUREZAS:

Caña / Shaft = HRC 64±2

HARDNESS:

Cabeza / Head = HRC 50±5

d1 (j6)	Incrementos de d1 d1 Increases	d2 (+0,-0,15)	d3 (m5)	r (+0,1-0)	l2 (+0,5-0)	l1 (+0,5+0,2)
1,6 a 5,9	0.1	9	6	0.3	10	71-80-90-100
2,5 a 7,9	0.1	11	8	0.3	13	71-80-90-100
4,0 a 9,9	0.1	13	10	0.3	17	71-80-90-100
5,0 a 12,9	0.1	16	13	0.4	17	71-80-90-100
8,0 a 15,9	0.1	19	16	0.4	17	71-80-90-100
12,0 a 19,5	0.5	24	20	0.4	17	80-90-100
16,5 a 24,5	0.5	29	25	0.4	17	80-90-100

SUMINISTRA BAJO DEMANDA.

AVAILABLE UNDER REQUEST

FORMA DE PEDIDO / ORDER FORM : F - HSS d1 x d3 x l1 x l2

PUNZON CABEZA CILINDRICA MECHADO FORMA "G" CON EXPULSOR INTERIOR, ISO 8020
STEPPED PUNCH WITH CYLINDRICAL HEAD TYPE "G" WITH SPRING LOADED EJECTOR PIN, ISO 8020

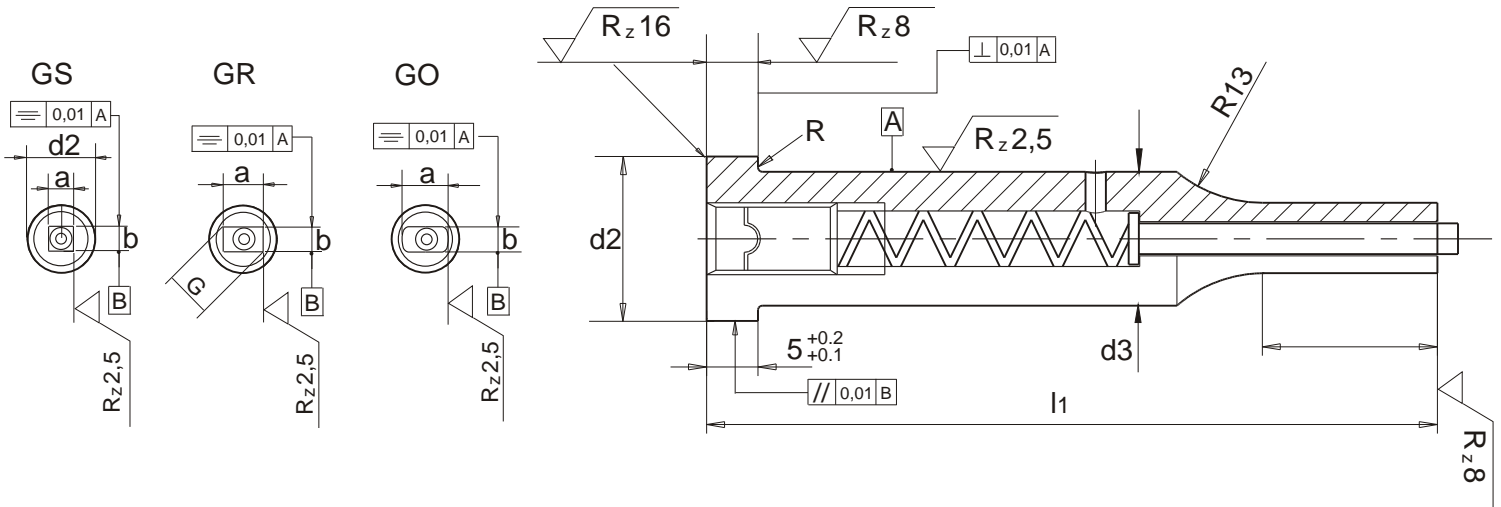

TIPOS / TYPES :

- Tipo / Type GS :** Mecha cuadrada con expulsor interior.
Square stepped shaft with ejector pin.
- Tipo / Type GR :** Mecha rectangular con expulsor interior.
Rectangular stepped shaft with ejector pin.
- Tipo / Type GO :** Mecha ovalada con expulsor interior.
Oblong stepped shaft with ejector pin.

CARACTERISTICAS :

Templado, rectificado y lapeado. Cabeza estampada en caliente. Ensamblado con muelle espiral especial, tornillo deslizante y expulsor. El muelle que aloja al expulsor es ajustable gracias al tornillo que lleva alojado en su cabeza.

VERSION:

Hardened, tempered, shaft fine ground finished. Completely assembled with coil spring, pin bolt and ejector. Spring pressure of ejector can be adjusted at pin bolt on head.

MATERIAL:

Acero rápido / HSS.

DUREZAS:

Caña / Shaft = HRC 64±2

HARDNESS:

Cabeza / Head = HRC 50±5

a (+0.01) b (+0.01)	d2 (+0-0.15)	d3 (m5)	r (+0,1-0)	l2 (+0.5-0)	l1 (+0.5+0.2)
El que quiera el cliente. On customer request. G = max d3	9	6	0.3	Dimensiones preferidas. Preferred sizes. 10, 13, 17. Otras longitudes disponibles bajo demanda. Other lengths under request.	71-80-90-100
	11	8	0.3		71-80-90-100
	13	10	0.4		71-80-90-100
	16	13	0.4		71-80-90-100
	19	16	0.4		71-80-90-100
	24	20	0.4		80-90-100
	29	25	0.4		80-90-100

SUMINISTRO BAJO DEMANDA. / AVAILABLE UNDER REQUEST.

FORMA DE PEDIDO / ORDER FORM : TIPO / TYPE = a x b x d3 x l2 x l1

PUNZON CUELLO DE BOTELLA “BN”
BOTTLE-NECK PUNCH “BN”

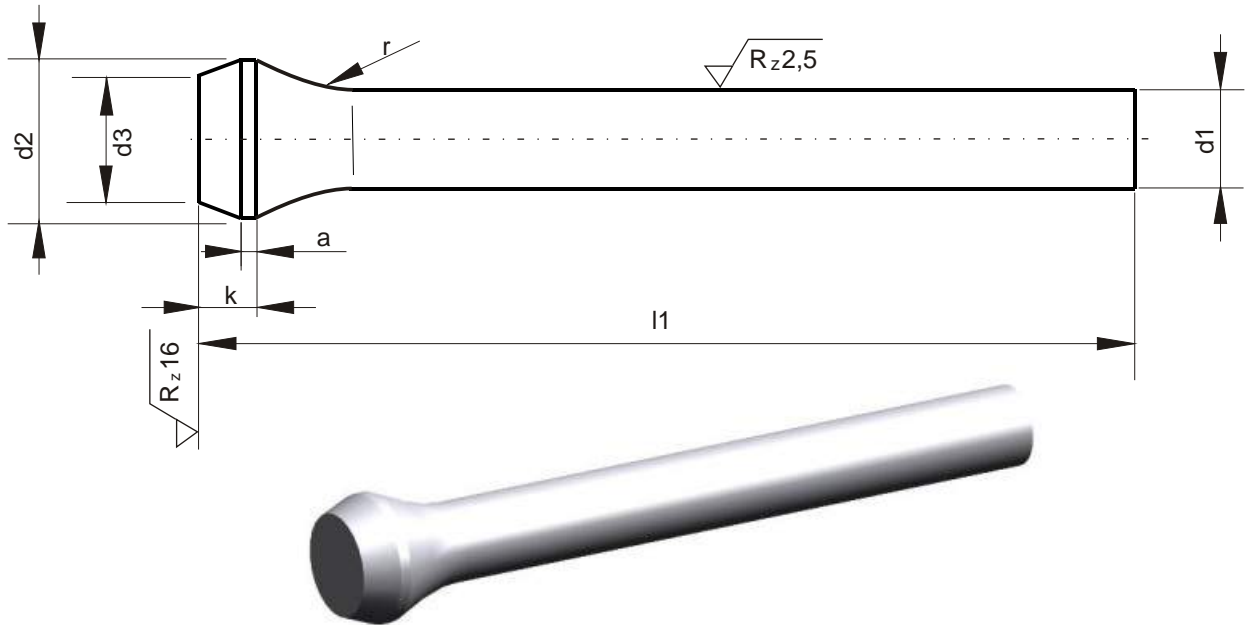

- CARACTERISTICAS:** Templado y lapeado en toda su longitud. Cabeza estampada en caliente y revenida.
- CHARACTERISTICS:** Hardened, tempered, fully fine ground finished, head hot folded and annealed.
- MATERIALES / MATERIALS:** HSS / CPM 10V
- DUREZA / HARDNESS :** Cuerpo / Shaft: Material HSS = HRC 64±2
 Material CPM 10V = HRC 62±2
 Cabeza / Head: Material HSS y and CPM 10V = HRC 50±5

d1 h6	Incre- mento Grad- ation d1	l1 +0,5 0	d2 0 -0,2	k + 0,2	a	d3	r 0 -0,2	d1 h6	Incre- mento Grad- ation d1	l1 +0,5 0	d2 0 -0,2	k + 0,2	a	d3	r 0 -0,2
desde from 2.0	0,1	71/ 80/ 100/	3.0	3.0	1.0	d1±0,1	8.0	desde from 7.5	0,1	71/ 80/ 100/	11.0	4.0	1,5	d1±0,2	12.0
desde from 2,1			3,2					3,5			desde from 8,5				13.0
desde from 2,3			3,5					5.0			desde from 9,5				14.0
desde from 2,6			4.0					6,5			desde from 10,5				15.0
desde from 3.0			4,5					8.0			desde from 11,5				16.0
desde from 3,5			5.0								desde from 12,5				17.0
desde from 4.0			5,5	desde from 13,5	18.0										
desde from 4,5			6.0	desde from 14,5	19.0										
desde from 5.0			7.0	desde from 15,5	20.0										
desde from 5,5			8.0	desde from 16,5	21.0										
desde from 6.0			9.0	desde from 17,5	22.0										
desde from 6,5			10.0	desde from 18,5	10.0										
			19,5-20.0	25.0											

FORMA DE PEDIDO / ORDER FORM : Material, d1 x l1

PUNZONES DE PRECISION FORMAS "AF" Y "BF"
PRECISION PUNCHES FORM "AF" AND "BF"

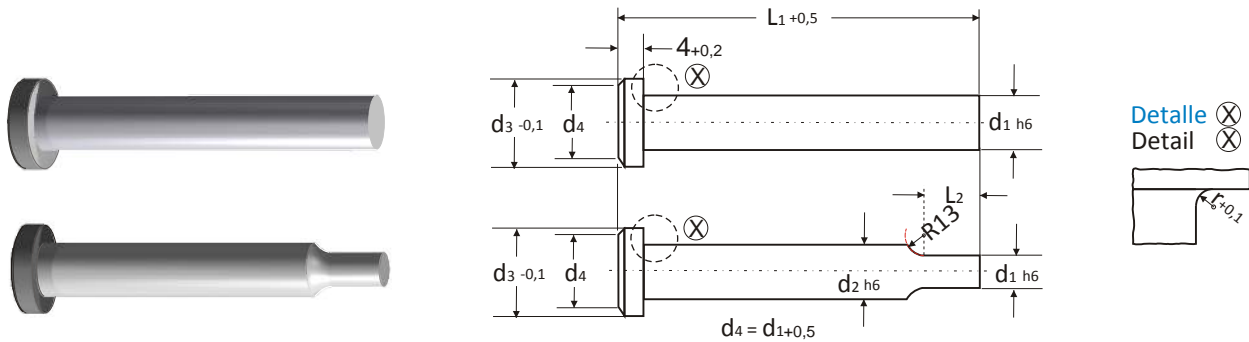

Acero Rapido HSS

Dureza Hardness: Cabeza Head: 64±2 HRC
 Cuerpo Shaft: 52±3 HRC

FABRICACION : Templado, revenido y rectificado totalmente.

VERSION : Hardened, tempered and fully fine ground finished.
 Cabeza estampada en caliente.
 Head hot tempered and annealed.

Forma AF		Intervalos		r	L1
d1	d1	d3	Intervalos		
2,0 - 2,2	0,1	3,6		0,2	60
2,3 - 2,5		4,0			
2,6 - 2,8		4,5		0,3	
2,9 - 3,2		5,0			
3,3 - 3,5		6,0			
3,6 - 4,0		7,0			
4,1 - 4,5		8,0		0,5	
4,6 - 5,0		8,5			
5,1 - 5,4		9,0			
5,5 - 5,9		9,5			
6,0 - 6,4		10,0			
6,5 - 7,0	0,5	10,8		0,7	
7,5 - 8,0		12,0			
8,5 - 9,0		13,0			
9,5 - 10,0		14,5			
10,5 - 11,0		16,0		1,0	
11,5 - 12,5		18,0			
13,0 - 14,0		20,0			
15,0 - 16,0		22,0			

Forma BF		Intervalos		L2	r	L1
d1	d1	d2	d3			
0,1 - 0,45	0,05	2,0	3,6	7	0,2	60
0,5 - 1,9						
1,95 - 2,4		2,5	4,0			
2,5 - 3,1	0,1	3,2	5,0		0,3	
3,2 - 3,9		4,0	7,0			
4,0 - 4,9		5,0	8,5		0,5	
5,0 - 6,2		6,3	10,0			
6,3 - 7,9		8,0	12,0	16	0,7	
8,0 - 9,9		10,0	14,5			
10,0 - 12,4		12,5	18,0		1,0	
12,5 - 15,9		16,0	22,0			

FORMA DE PEDIDO: d1 x L1 ORDER FORM: d1 x L1

PUNZONES FORMA "DA" CON/SIN CABEZA - Cuadrados y Rectangulares PUNCHES FORM "DA" HEADED/HEADLESS - Squared and Rectangular

TIPO CS - CUADRADO SIN CABEZA TYPE CS - SQUARE HEADLESS

MATERIAL: 12% Cromo y Ac. Rapido. *HWS & HSS*
FABRICACION: Templado, revenido y rectificado.
VERSION: Hardened, tempered and fully fine ground finished
DUREZAS: *HWS: 60 - 64 HRC.*
HARDNESS: *HSS: 62 - 66 HRC.*

a (-0,01)	l + 0,5
1,0 a 12,0	71 mm.

FORMA DE PEDIDO / ORDER FORM : a.

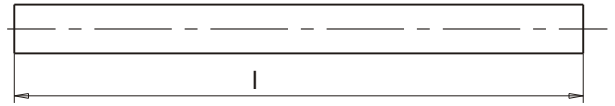
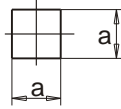

TIPO CC - CUADRADO CON CABEZA TYPE CC - SQUARE HEADED

MATERIAL: 12% Cromo y Ac. Rapido. *HWS & HSS*
FABRICACION: Templado, revenido y rectificado.
VERSION: Hardened, tempered and fully fine ground finished.
DUREZAS: *HWS: 60 - 64 HRC.*
HARDNESS: *HSS: 62 - 66 HRC.*

a (-0,01)	l + 0,5
0,5 a 12,0	71 mm.

FORMA DE PEDIDO / ORDER FORM : a.

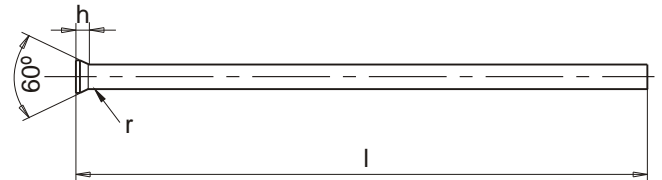
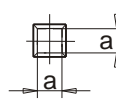

TIPO RS - RECTANGULAR SIN CABEZA TYPE RS - RECTANGULAR HEADLESS

MATERIAL: 12% Cromo y Ac. Rapido. *HWS & HSS*
FABRICACION: Templado, revenido y rectificado.
VERSION: Hardened, tempered and fully fine ground finished.
DUREZAS: *HWS: 60 - 64 HRC.*
HARDNESS: *HSS: 62 - 66 HRC.*

a (-0,01)	b (-0,01)	l + 0,5
1,0 a 34,0	0,5 a 12,0	71 mm.

FORMA DE PEDIDO / ORDER FORM : a x b

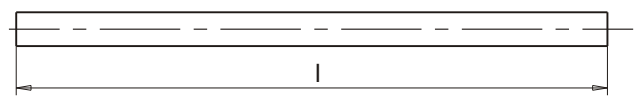
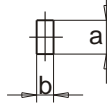

TIPO RC - RECTANGULAR CON CABEZA TYPE RC - RECTANGULAR HEADED

MATERIAL: 12% Cromo y Ac. Rapido. *HWS & HSS*
FABRICACION: Templado, revenido y rectificado.
VERSION: Hardened, tempered and fully fine ground finished.
DUREZAS: *HWS: 60 - 64 HRC.*
HARDNESS: *HSS: 62 - 66 HRC.*

a (-0,01)	b (-0,01)	l + 0,5
1,0 a 34,0	0,5 a 12,0	71 mm.

FORMA DE PEDIDO / ORDER FORM : a x b

SUMINISTRABLE BAJO PEDIDO / AVAILABLE UNDER REQUEST.

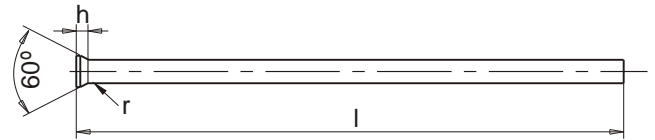
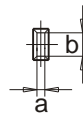

PUNZONES ESPECIALES CON FORMAS ESPECIALES

PRECISION PUNCHES WITH SPECIAL SHAPES

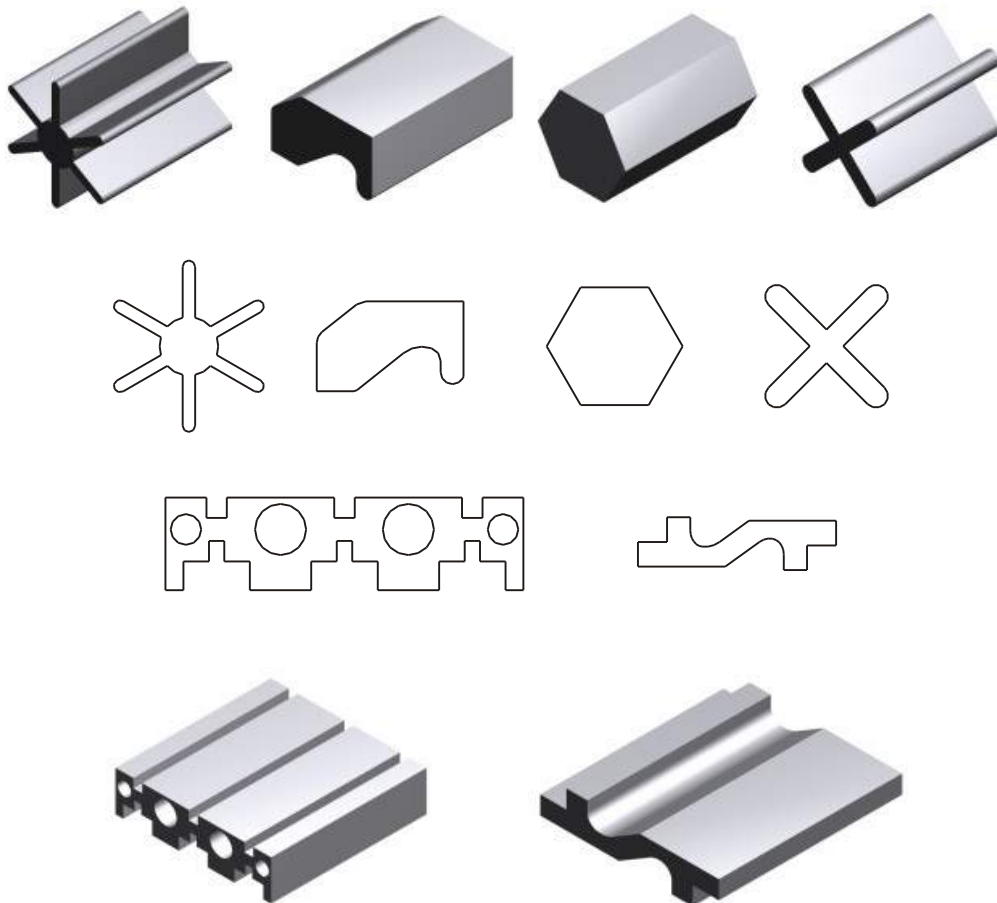

MATERIAL:	12% Cromo, HWS y Ac. Rapido, HSS .
EJECUCION:	Templado, revenido y finamente rectificad.
VERSION	<i>Hardened. tempered, fully fine ground finished.</i>
TOLERANCIA:	0,01 mm. Longitud / Length + 0,5 mm.
TOLERANCE:	
FABRICACION:	Según plano.
PRODUCTION:	<i>Available according to your drawing or sketch.</i>

CASQUILLO MATRIZ DE CORTE LISO NIN 1A / DIN 9845-A HEADLESS PRECISION DIE BUSHES NIN 1A / DIN 9845-A

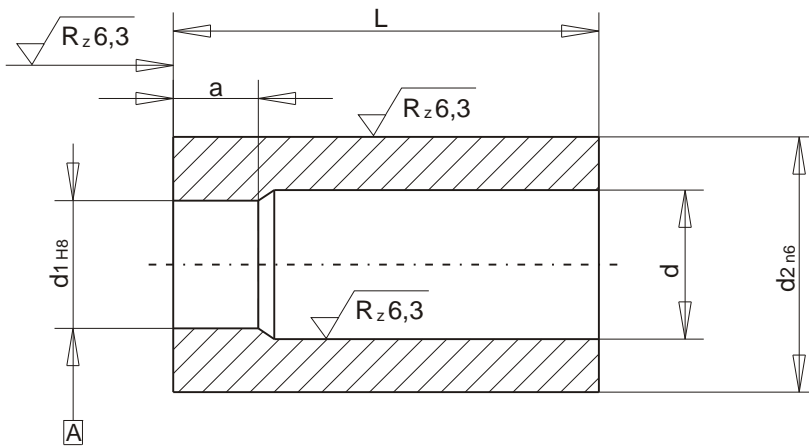

MATERIAL:	12% Cromo / HWS. Acero Rápido / HSS
DUREZA:	12% Cromo HWS: 60±2 HRC.
HARDNESS:	Acero rápido HSS: 62±2 HRC.
TOLERANCIAS:	d1 = H8
TOLERANCES:	d2 = n6

d1 (H8)	incr. d1	d2 (n6)	d (+0,1)	L (+0,5-0)	a
1	0.1	6	d1+0,6	20	3
1,1 a 1,8	0.1	6	d1+0,6	20 - 28	3
1,9 a 2,6	0.1	7	d1+0,6	20 - 28	3
2,7 a 3,3	0.1	7	d1+0,6	20 - 28	3
3,4 a 4,0	0.1	8	d1+0,6	20 - 28	3
4,1 a 5,0	0.1	10	d1+1,0	20 - 28	3
5,1 a 6,0	0.1	12	d1+1,0	20 - 28	4
6,1 a 8,0	0.1	15	d1+1,0	20 - 28	4
8,1 a 10,0	0.1	18	d1+1,0	20 - 28	4
10,1 a 12,0	0.1	22	d1+1,0	20 - 28	5
12,1 a 15,0	0.1	26	d1+1,0	20 - 28	5

FORMA DE PEDIDO / ORDER FORM: d1 x L.

También disponibles los incrementos de d1 en ,25 y ,75.

Also available d1 increases in ,25 and ,75.

NOTA : También disponibles casquillos en las siguientes medidas:

NOTE : Also available bushes with the following sizes.

d1 = 1	d2 = 5
d1 = 1,9 y 2	d2 = 6
d1 = 3,1 - 3,2 - 3,3	d2 = 8

CASQUILLO MATRIZ DE CORTE CON VALONA NIN 1B / DIN 9845-B HEADED PRECISION DIE BUSHES NIN 1B / DIN 9845-B

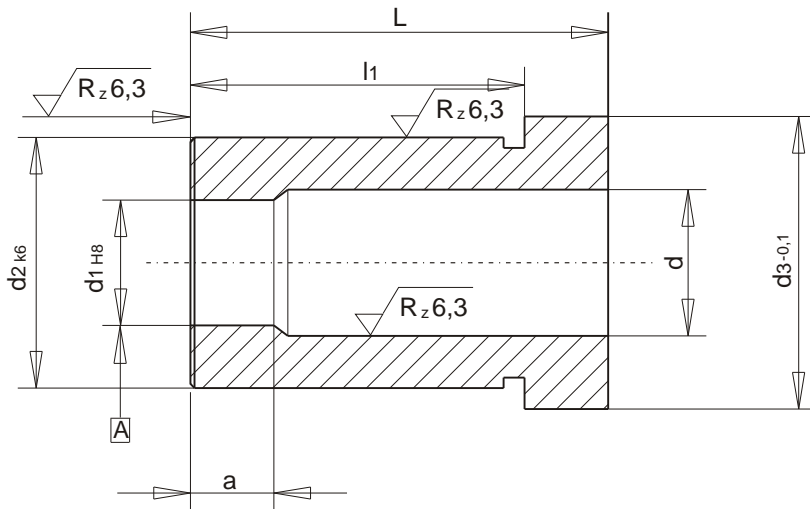

MATERIAL: 12% Cromo / HWS.
Acero Rápido / HSS.

DUREZA: 12% Cromo / HWS: 60±2 HRC.
HARDNESS: Acero Rápido / HSS: 62±2 HRC.

TOLERANCIAS: d1 = H8
TOLERANCES: d2 = n6

d1 (H8)	incr. d1	d2 (k6)	d3 (-0,1)	d (+0,1)	L (+0,5-0)		a		L1	
1	0.1	6	8	d1+0,6	20	20	3		16	16
1,1 a 1,8	0.1	6	8	d1+0,6	20	28	3		16	24
1,9 a 2,6	0.1	7	9	d1+0,6	20	28	3		16	24
2,7 a 3,3	0.1	7	9	d1+0,6	20	28	3		16	24
3,4 a 4,0	0.1	8	10	d1+0,6	20	28	3		16	24
4,1 a 5,0	0.1	10	12	d1+1,0	20	28	3		16	24
5,1 a 6,0	0.1	12	14	d1+1,0	20	28	4		16	24
6,1 a 8,0	0.1	15	17	d1+1,0	20	28	4		16	24
8,1 a 10,0	0.1	18	20	d1+1,0	20	28	4		16	24
10,1 a 12,0	0.1	22	24	d1+1,0	20	28	5		16	24
12,1 a 15,0	0.1	26	28	d1+1,0	20	28	5		16	24

FORMA DE PEDIDO / ORDER FORM: d1 x L.
También disponibles los incrementos de d1 en ,25 y ,75.
Also available d1 increases in ,25 and ,75.

NOTA : También disponibles casquillos en las siguientes medidas:
NOTE : Also available bushes with the following sizes.

d1 = 1 d2 = 5
d1 = 1,9 y 2 d2 = 6
d1 = 3,1 - 3,2 - 3,3 d2 = 8

CASQUILLO GUIA PUNZON NIN 2A / DIN 9845-C PRECISION GUIDE BUSHES NIN 2A / DIN 9845-C

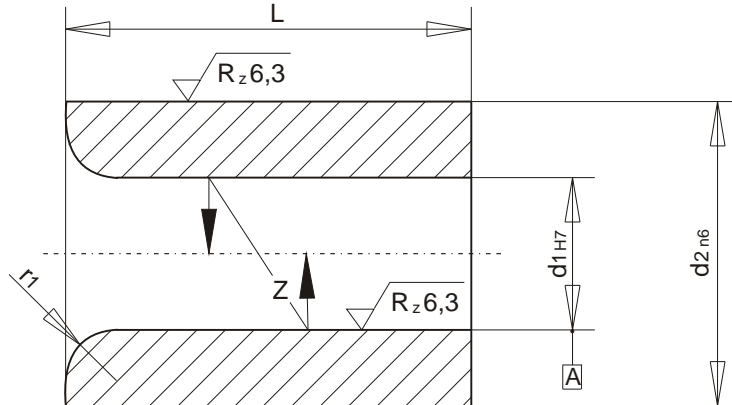

MATERIAL:	Acero aleado al 12% Cromo.
MATERIAL:	HWS.
FABRICACION:	Templado. Diámetro interior y exterior rectificadas.
VERSION:	Hardened and tempered bore and outside diameter grounded.
DUREZA:	62 - 64 Hrc.
HARDNESS:	
TOLERANCIAS:	d1 = H7
TOLERANCES:	d2 = n6

d1 (H7)	incr. d1	d2 (n6)	Z	r1	L
1,1 a 1,8	0.1	6	0.005	1.2	12
1,9 a 2,6	0.1	7	0.005	1.2	12
2,7 a 3,3	0.1	7	0.005	1.6	12
3,4 a 4,0	0.1	8	0.005	1.6	12
4,1 a 5,0	0.1	10	0.005	2	16
5,1 a 6,0	0.1	12	0.01	2	16
6,1 a 8,0	0.1	15	0.01	2	20
8,1 a 10,0	0.1	18	0.01	2.5	20
10,1 a 12,0	0.1	22	0.01	2.5	28
12,1 a 15,0	0.1	26	0.01	4	28
15,5 a 18,0	0.5	30	0.01	5	36

FORMA DE PEDIDO / ORDER FORM: d1

También disponibles los incrementos de d1 en ,25 y ,75.

Also available d1 increases in ,25 and ,75.

NOTA : También disponibles casquillos en las siguientes medidas:

NOTE : Also available bushes with the following sizes.

d1 = 1,9 y 2 d2 = 6

d1 = 3,1 - 3,2 - 3,3 d2 = 8

MATRICES CON AGUJERO INICIO ISO 8977A

MATRIXES WITH START BORE ISO 8977A

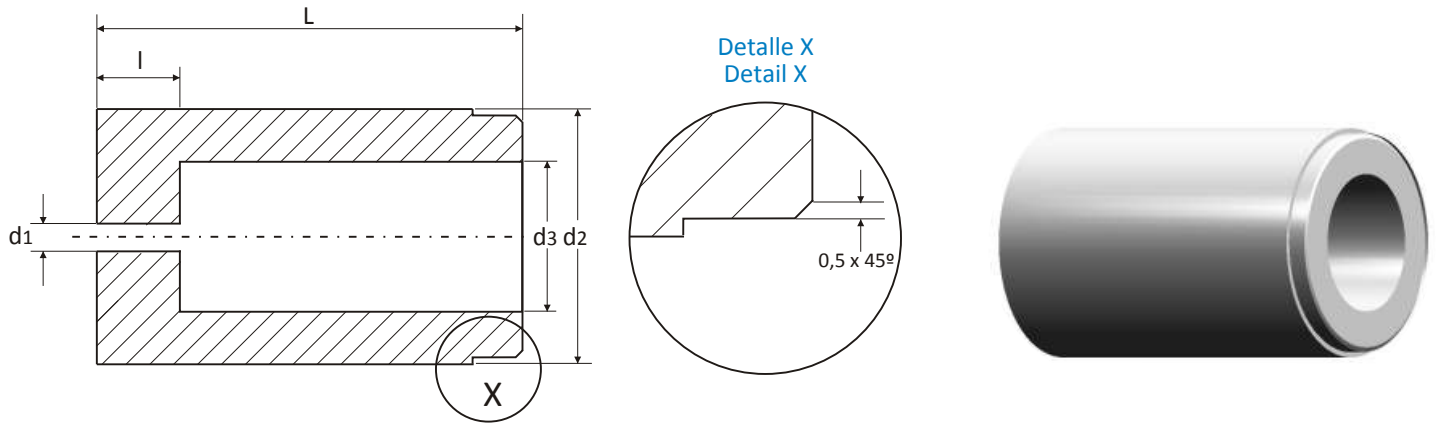

MATERIAL: Acero Rápido / HSS
TRATAMIENTO TERMICO: Templados
HEAT TREATMENT: Hardened
DUREZA: 63-65 HRC.
HARDNESS:

d2 (ns)	d1	L (+0/+0,5)	d3	l
5	1,0	16	2,8	2,0
6	1,0		3,5	3,0
8	1,0		4,0	4,0
10	1,0		5,8	4,0
13	1,2	20	8,0	5,0
16	1,2	25	9,5	5,0
20	1,5	32	12	8,0
25	1,5		17,3	8,0
32	1,5		20,7	8,0
40	1,5		27,7	8,0

FORMA DE PEDIDO: d2 x L **ORDER FORM:** d2 x L

MATRICES CON AGUJERO INICIO ISO 8977B MATRIXES WITH START BORE ISO 8977B

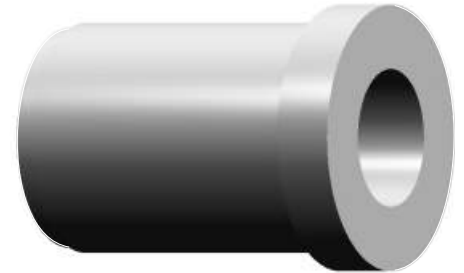
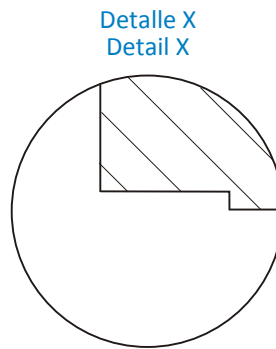
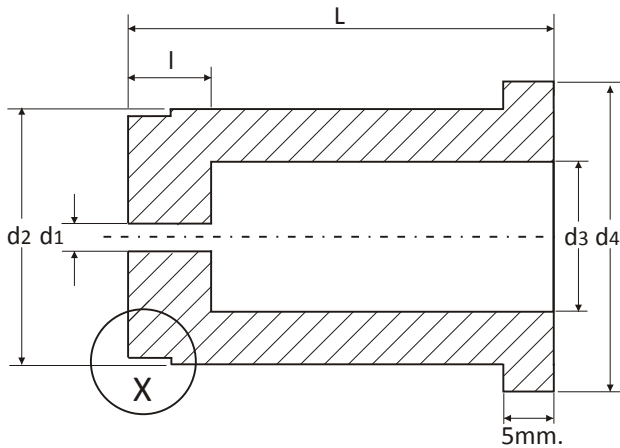

MATERIAL: Acero Rápido / HSS
TRATAMIENTO TERMICO: Templados
HEAT TREATMENT: Hardened
DUREZA: 63-65 HRC.
HARDNESS:

d2 (ns)	d1	L (+0/+0,5)	d4	d3	l
5	1,0	16	8	2,8	2
6	1,0		9	3,5	3
8	1,0		11	4,0	4
10	1,0	20	13	5,8	4
13	1,2		16	8,0	5
16	1,2	25	19	9,5	5
20	1,5		24	12	8
25	1,5	32	29	17,3	8
32	1,5		36	20,7	8
40	1,5		44	27,7	8

FORMA DE PEDIDO: d2 x L **ORDER FORM:** d2 x L

CASQUILLO DE CORTE CON VALONA, CON FORMA Y LOCALIZADOR - ISO 8977
HEADED SHAPED DIE BUSHES - ISO 9877

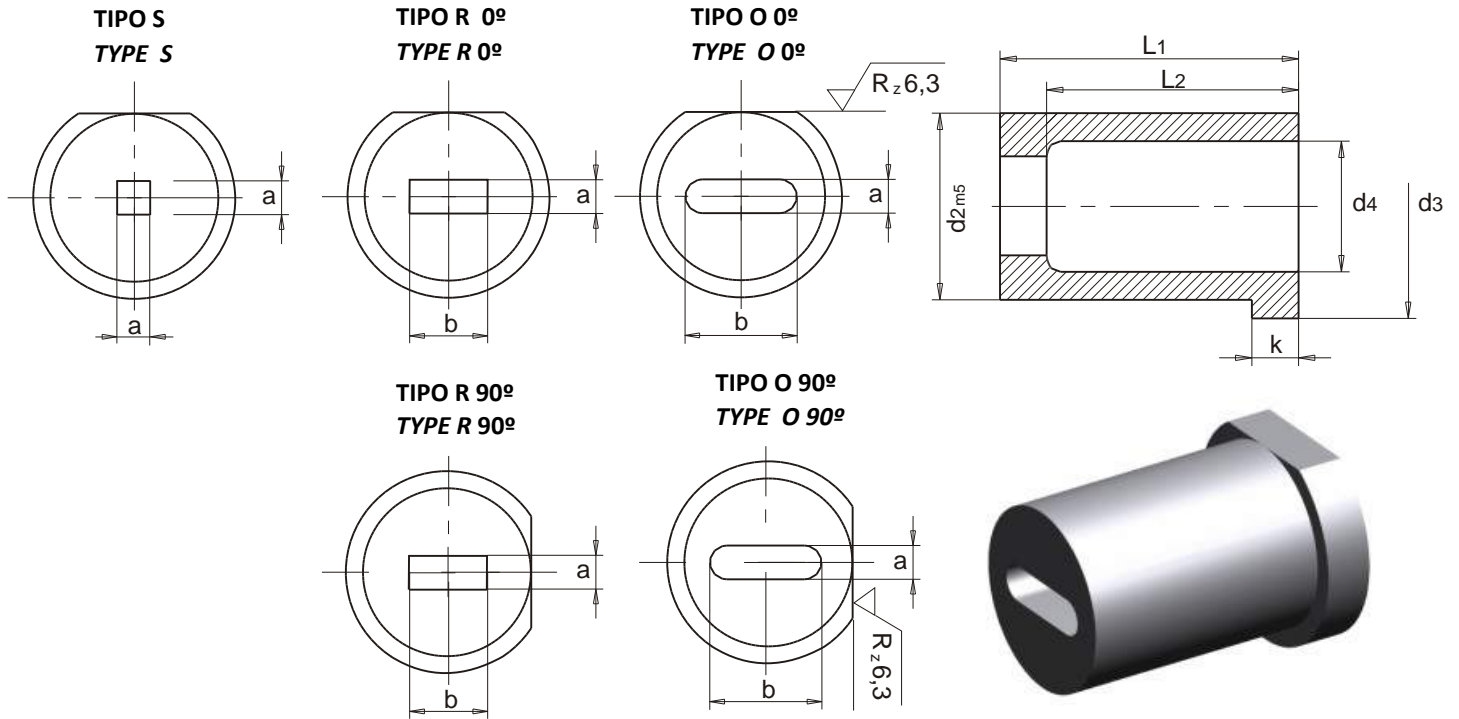

TIPO S / TYPE S:

Forma corte cuadrada. Square shape.

TIPO R / TYPE R:

Forma corte rectangular. Rectangular shape.

TIPO O / TYPE O:

Forma corte oblonga. Oblong shape

LOCALIZADOR:

El plano localizador está siempre posicionado en el lado más largo, salvo indicación en contra.

LOCATING FLAT:

The locating flat is always positioned on the longest side unless otherwise stated.

MATERIAL / MATERIAL:

12% Cromo / HWS

DUREZA / HARDNESS:

62±2 HRC.

a (H8)	b (H8)	incred. increas.	d2 (m5)	d3	d4	k (+0,25-0)	l1 (+0,5-0)	l2
1,6 a 5,4	2,0 a 5,5	0.1	10	13	6.5	5	32	29
2,0 a 7,4	2,5 a 7,5	0.1	13	16	8.5	5	32	28
2,2 a 9,9	2,5 a 10,0	0.1	16	19	11	5	32	28
2,5 a 12,9	3,2 a 13,0	0.1	20	24	14	5	32	27
3,2 a 15,9	4,0 a 16,0	0.1	25	29	17	5	32	27
4,0 a 20,9	5,0 a 21,0	0.1	32	36	22	5	32	26
5,0 a 26,9	6,3 a 27,0	0.1	40	44	28	5	32	24

FORMA DE PEDIDO:

Tipo, a x b x d2 x l1 x Grados.

ORDER FORM :

Type, a x b x d2 x l1 x Degrees.

PUNZONES LAGRIMA CARGA FUERTE STANDARD HEAVY DUTY REGULAR PUNCHES

TIPO TYPE: EBP

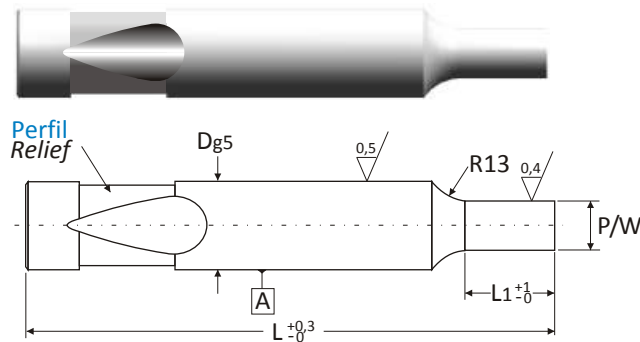

MATERIAL: Acero Steel: HSS
60-63 Hrc.

POSICION STANDARD ASIEN TO BOLA

La posición standard asiento bola es 90°. Alternativamente pueden ser 0°, 180° o 270°, si se especifica

STANDARD BALL SEAT LOCATIONS

Standard Ball Seat Location is at 90°. Alternate locations of 0°, 180°, or 270°, can be specified.

POSICION PERSONALIZADA ASIEN TO BOLA

Puede ser especificada como BS y los grados contarlos en sentido de las agujas del reloj, partiendo de 0°.

CUSTOM BALL SEAT LOCATIONS

Custom Ball Seat Locations can be specified as BS and degrees counter-clockwise from 0°.

EBPH

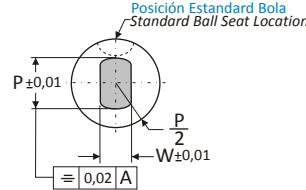

EBPK

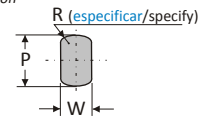

EBPJ

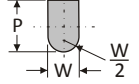

EBPX

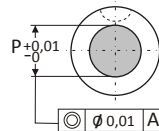

EBPO

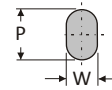

EBPR

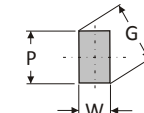

EBPL

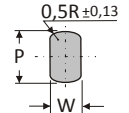

POSICIONES DOBLE ASIEN TO BOLA

Un segundo asiento bola, puede ser requerido. Normalmente ubicado a 180° del primer asiento. Especificar SB y los grados deseados. Pueden estar localizados tambien a 90° del primer asiento. No recomendable para diametros de caña menores a 20 mm.

DOUBLE BALL SEAT LOCATIONS

A second ball seat can be specified. Normally located 180° from the primary ball seat these are used to minimize sharpening of notching punches by rotating the punch 180°. Specify SB and degree desired. Can also be located 90° from primary ball seat. Non recommended for shank diameters under 20 mm.

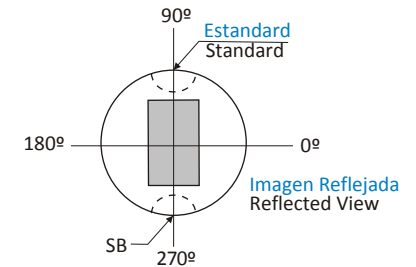
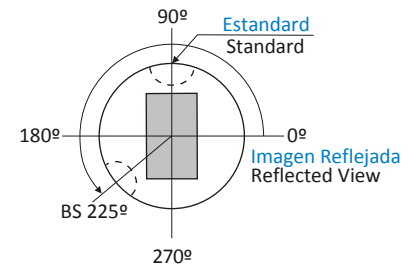

D	Longitud L1 Point Length L1			Tipo Type	Rango Diam. Round Range	Tipo Type	Forma Shape	L								
	Std. S	Alt. A	Alt. B					& D	P	& D	Min. W	Max. P/G	63	71	80	90
10	19	10*	--	EBPX10	2.10- 9.97	EBP_10	2.10- 9.97	*	*	*	*	*	*	*	*	*
13	19	13	25	EBPX13	5.00-12.97	EBP_13	4.50-12.97	*	*	*	*	*	*	*	*	*
16	19	13	25	EBPX16	8.00-15.97	EBP_16	6.00-15.97	*	*	*	*	*	*	*	*	*
20	19	13	25	EBPX20	12.00-19.97	EBP_20	8.00-19.97	*	*	*	*	*	*	*	*	*
25	19	13	25	EBPX25	16.00-24.97	EBP_25	10.00-24.97		*	*	*	*	*	*	*	*
32	19	13	25	EBPX32	24.00-31.97	EBP_32	12.50-31.97		*	*	*	*	*	*	*	*
40	25	19	30	EBPX40	30.00-39.97	EBP_40	14.00-39.97			*	*	*	*	*	*	*

* Min. P o W = 1.60 cuando L1 = 10

* Min. P or W = 1.60 when L1 = 10

Alt. B no disponible.
Alt. B not available.

FORMA DE PEDIDO: Tipo x D x L1 x L x P/W
ORDER FORM: Type x D x L1 x L x P/W

PUNZONES LAGRIMA CARGA LIGERA STANDARD LIGHT DUTY REGULAR PUNCHES

TIPO: ECP TYPE ECP

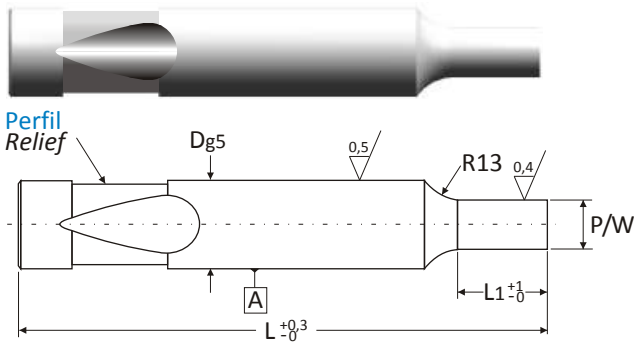

MATERIAL: Acero Steel: HWS - HSS 60-63 HRc.

POSICION STANDARD ASIEN TO BOLA

La posición standard asiento bola es 90°. Alternativamente pueden ser 0°, 180° o 270°, si se especifica

STANDARD BALL SEAT LOCATIONS

Standard Ball Seat Location is at 90°. Alternate locations of 0°, 180°, or 270°, can be specified.

POSICION PERSONALIZADA ASIEN TO BOLA

Puede ser especificada como BS y los grados contarlos en sentido de las agujas del reloj, partiendo de 0°.

CUSTOM BALL SEAT LOCATIONS

Custom Ball Seat Locations can be specified as BS and degrees counter-clockwise from 0°.

ECPH

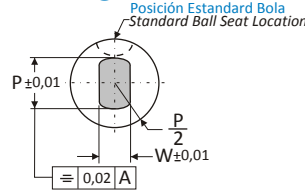

ECPK

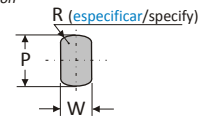

ECPJ

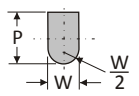

ECPX

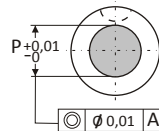

ECPO

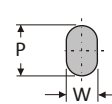

ECPR

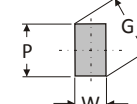

ECPL

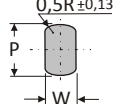

POSICIONES DOBLE ASIEN TO BOLA

Un segundo asiento bola, puede ser requerido. Normalmente ubicado a 180° del primer asiento. Especificar SB y los grados deseados. Pueden estar localizados también a 90° del primer asiento. No recomendable para diámetros de caña menores a 20 mm.

DOUBLE BALL SEAT LOCATIONS

A second ball seat can be specified. Normally located 180° from the primary ball seat these are used to minimize sharpening of notching punches by rotating the punch 180°. Specify SB and degree desired. Can also be located 90° from primary ball seat. Non recommended for shank diameters under 20 mm.

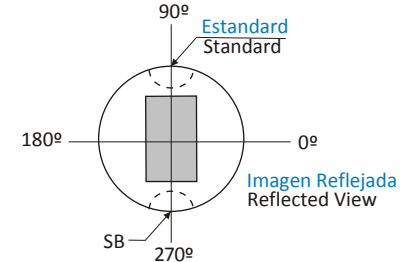
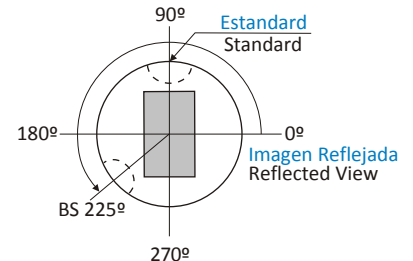

D	Longitud L1 Point Length L1			Tipo Type	Rango Diam. Round Range	Tipo Type	Forma Shape	L						
	Std. S	Alt. A	Alt. B					& D	P	& D	Min. W	Max. P/G	63	71
06	13	10*	--	ECPX06	2.10- 5.97	ECP_06	2.10- 5.97	*	*	*	*	*	*	*
10	19	10*	--	ECPX10	2.10- 9.97	ECP_10	2.10- 9.97	*	*	*	*	*	*	*
13	19	13	25	ECPX13	5.00-12.97	ECP_13	4.50-12.97	*	*	*	*	*	*	*
16	19	13	25	ECPX16	8.00-15.97	ECP_16	6.00-15.97	*	*	*	*	*	*	*
20	19	13	25	ECPX20	12.00-19.97	ECP_20	8.00-19.97	*	*	*	*	*	*	*
25	19	13	25	ECPX25	16.00-24.97	ECP_25	10.00-24.97	*	*	*	*	*	*	*
32	19	13	25	ECPX32	24.00-31.97	ECP_32	12.50-31.97		*	*	*	*	*	*
38	25	19	30	ECPX38	30.00-37.97	ECP_38	14.00-37.97				*	*	*	*

* Min. P o W = 1.60 cuando L1 = 10 * Min. P or W = 1.60 when L1 = 10

FORMA DE PEDIDO: Tipo x D x L1 x L x P/W x Acero ORDER FORM: Type x D x L1 x L x P/W x Steel

PUNZONES LAGRIMA CARGA FUERTE CON EXPULSOR HEAVY DUTY BALL LOCK PUNCHES WITH EJECTOR

TIPO TYPE: EBJ

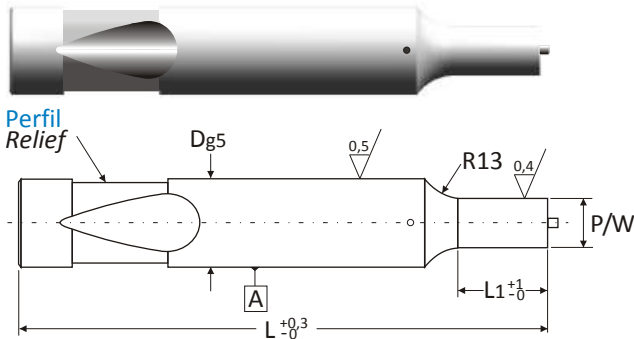

MATERIAL: Acero Steel: HSS
60-63 Hrc.

EBJH

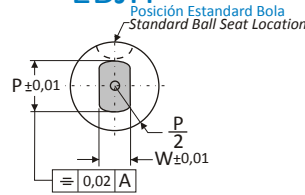

EBJK

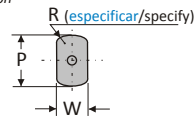

EBJJ

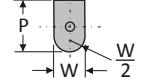

EBJX

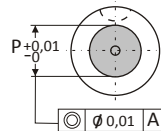

EBJO

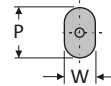

EBJR

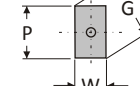

EBJL

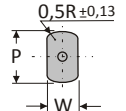

D	Longitud L1 Point Length L1			Tipo Type	Rango Diam. Round Range	Tipo Type	Forma Shape	L							Pin		
	Std. S	Alt. A	Alt. B					& D	P	& D	Min. W	Max. P/G	63	71		80	90
10	19	10*	--	EBJX10	2.10- 9.97	EBJ_10	2.10- 9.97	*	*	*	*	*	*	*	*	*	J4M *
13	19	13	25	EBJX13	5.00-12.97	EBJ_13	4.50-12.97	*	*	*	*	*	*	*	*	*	J6M
16	19	13	25	EBJX16	8.00-15.97	EBJ_16	6.00-15.97	*	*	*	*	*	*	*	*	*	J6M
20	19	13	25	EBJX20	12.00-19.97	EBJ_20	8.00-19.97	*	*	*	*	*	*	*	*	*	J9M
25	19	13	25	EBJX25	16.00-24.97	EBJ_25	10.00-24.97		*	*	*	*	*	*	*	*	J9M
32	19	13	25	EBJX32	24.00-31.97	EBJ_32	12.50-31.97		*	*	*	*	*	*	*	*	J12M
40	25	19	30	EBJX40	30.00-39.97	EBJ_40	14.00-39.97			*	*	*	*	*	*	*	J12M

* Min. P o W = 1.60 cuando L1 = 10
* Min. P or W = 1.60 when L1 = 10

Alt. B no disponible.
Alt. B not available.

* J2 (P<3.0)

L Max.	Alteraciones Standard						Standard Alterations					
	EXBR			EXBB			EXBR			EXBB		
D	13	19	25	30	35	40	13	19	25	30	35	40
	Diametro P minimo Minimum P Rounds						Formas W minimas Minimum W Shapes					
10	1,4	1,5	2,4	3,2	4,0	5,0	1,4	1,5	2,4	4,0	4,0	5,0
13	4,0	4,0	4,0	4,0	4,0	5,0	4,0	4,0	4,0	4,0	4,5	5,0
16	4,0	4,0	4,0	4,0	4,0	6,0	4,0	4,0	4,0	4,0	4,5	6,0
20	6,0	6,0	6,0	7,6	7,6	7,6	6,0	6,0	6,0	6,0	6,0	6,0
25	8,0	8,0	8,0	10,0	10,0	10,0	6,0	6,0	6,0	6,0	6,0	6,0
32	10,0	10,0	10,0	10,0	10,0	10,0	7,2	7,2	7,2	7,2	7,2	7,2
40	12,0	12,0	12,0	12,0	12,0	12,0	7,2	7,2	7,2	7,2	7,2	7,2

EXBR

Longitud mecha mas larga que standard
Especificar EXPR o EXBB y la longitud
(Ver tabla a la izquierda)

Point Length Longer than Standard
Specify EXBR or EXBB and length
(See chart at left)

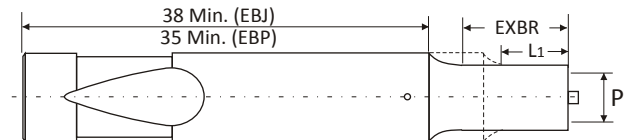

EXL

Longitud total mas corta
La medida se acorta en la mecha.
Para mantener la longitud de mecha, especificar EXBR
Overall Length Shortened
Stock removal from point end which shortens point
Length. To maintain point length specify EXBR

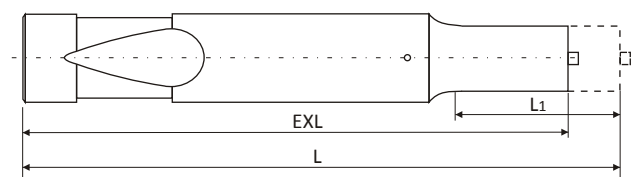

EXP, EXW Pedidos P o W Menores que el Standard
P or W Dimensions Smaller than Standard

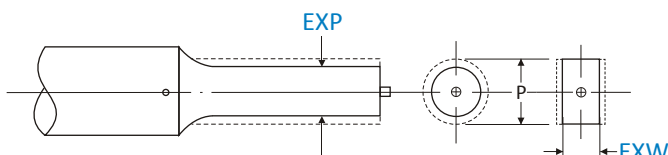

FORMA DE PEDIDO ORDER FORM: Tipo x D x L1 x L x P (P,W) Type x D x L1 x L x P (P,W)

PUNZONES LAGRIMA CARGA LIGERA CON EXPULSOR LIGHT DUTY BALL LOCK PUNCHES WITH EJECTOR

TIPO TYPE: ECJ

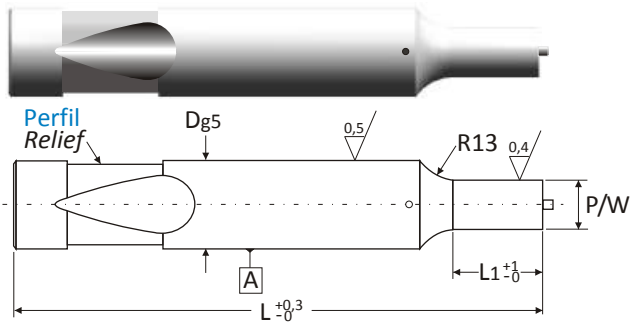

MATERIAL: Acero Steel: HWS, HSS 60-63 Hrc.

ECJH

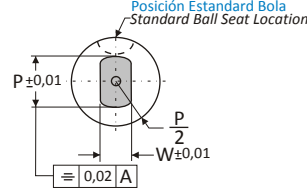

ECJK

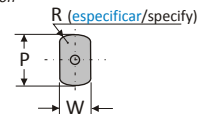

ECJL

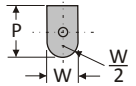

ECJX

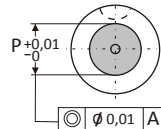

ECJO

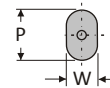

ECJR

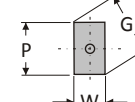

ECJL

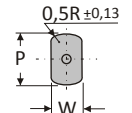

D	Longitud L1 Point Length L1			Tipo Type	Rango Diam. Round Range	Tipo Type	Forma Shape	L						Pin	
	Std. S	Alt. A	Alt. B					& D	P	& D	Min. W	Max. P/G	63		71
06	13	10*	--	ECJX06	2.10- 5.97	ECJ_06	2.10- 5.97	*	*	*	*	*	*		J3M **
10	19	10*	--	ECJX10	2.10- 9.97	ECJ_10	2.10- 9.97	*	*	*	*	*	*	*	J4M *
13	19	13	25	ECJX13	5.00-12.97	ECJ_13	4.50-12.97	*	*	*	*	*	*	*	J6M
16	19	13	25	ECJX16	8.00-15.97	ECJ_16	6.00-15.97	*	*	*	*	*	*	*	J6M
20	19	13	25	ECJX20	12.00-19.97	ECJ_20	8.00-19.97	*	*	*	*	*	*	*	J9M
25	19	13	25	ECJX25	16.00-24.97	ECJ_25	10.00-24.97	*	*	*	*	*	*	*	J9M
32	19	13	25	ECJX32	24.00-31.97	ECJ_32	12.50-31.97		*	*	*	*	*	*	J12M
38	25	19	30	ECJX38	30.00-37.97	ECJ_38	14.00-37.97			*	*	*	*	*	J12M

* Min. P o W = 1.60 cuando L1 = 10 * Min. P or W = 1.60 when L1 = 10

** J2 (P<2.0) * J2 (P<3.0)

Alteraciones Standard para Punzones ECJ y ECP Standard Alterations for ECJ and ECP Punches												
L Max.	EXBR					EXBB					D	
	13	19	25	30	35	40	13	19	25	30		35
	Diametro P minimo Minimum P Rounds					Formas W minimas Minimum W Shapes						
06	1,4	1,4	2,0	2,5	--	--	1,4	1,4	2,0	3,0	--	--
10	1,4	1,5	2,4	3,2	4,0	5,0	1,4	1,5	2,4	4,0	4,0	5,0
13	4,0	4,0	4,0	4,0	4,0	5,0	4,0	4,0	4,0	4,0	4,5	5,0
16	4,0	4,0	4,0	4,0	4,0	6,0	4,0	4,0	4,0	4,0	4,5	6,0
20	6,0	6,0	6,0	7,6	7,6	7,6	6,0	6,0	6,0	6,0	6,0	6,0
25	8,0	8,0	8,0	10,0	10,0	10,0	6,0	6,0	6,0	6,0	6,0	6,0
32	10,0	10,0	10,0	10,0	10,0	10,0	7,2	7,2	7,2	7,2	7,2	7,2
38	12,0	12,0	12,0	12,0	12,0	12,0	7,2	7,2	7,2	7,2	7,2	7,2

EXP, EXW Pedidos P o W Menores que el Standard
P or W Dimensions Smaller than Standard

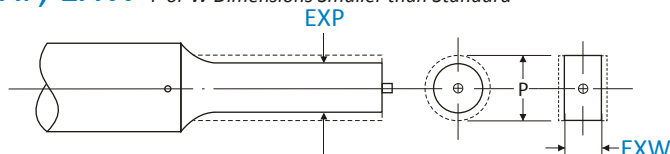

FORMA DE PEDIDO ORDER FORM: Tipo x D x L1 x L x P (P,W) Type x D x L1 x L x P (P,W)

EXBR Longitud mecha mas larga que standard
Especificar EXPR o EXBB y la longitud
(Ver tabla a la izquierda)

Point Length Longer than Standard
Especify EXBR or EXBB and length
(See chart at left)

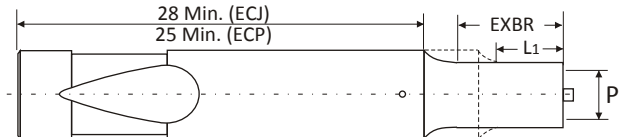

EXL Longitud total mas corta
La medida se acorta en la mecha.
Para mantener la longitud de mecha, especificar EXBR
Overall Length Shortened
Stock removal from point end which shortens point
Length. To maintain point length specify EXBR

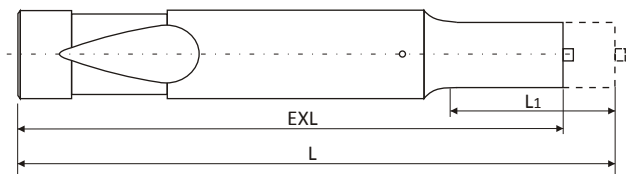

PORTA-PUNZONES CABEZA CILINDRICA " HHR "

CYLINDRICAL HEAD PUNCH RETAINERS " HHR "

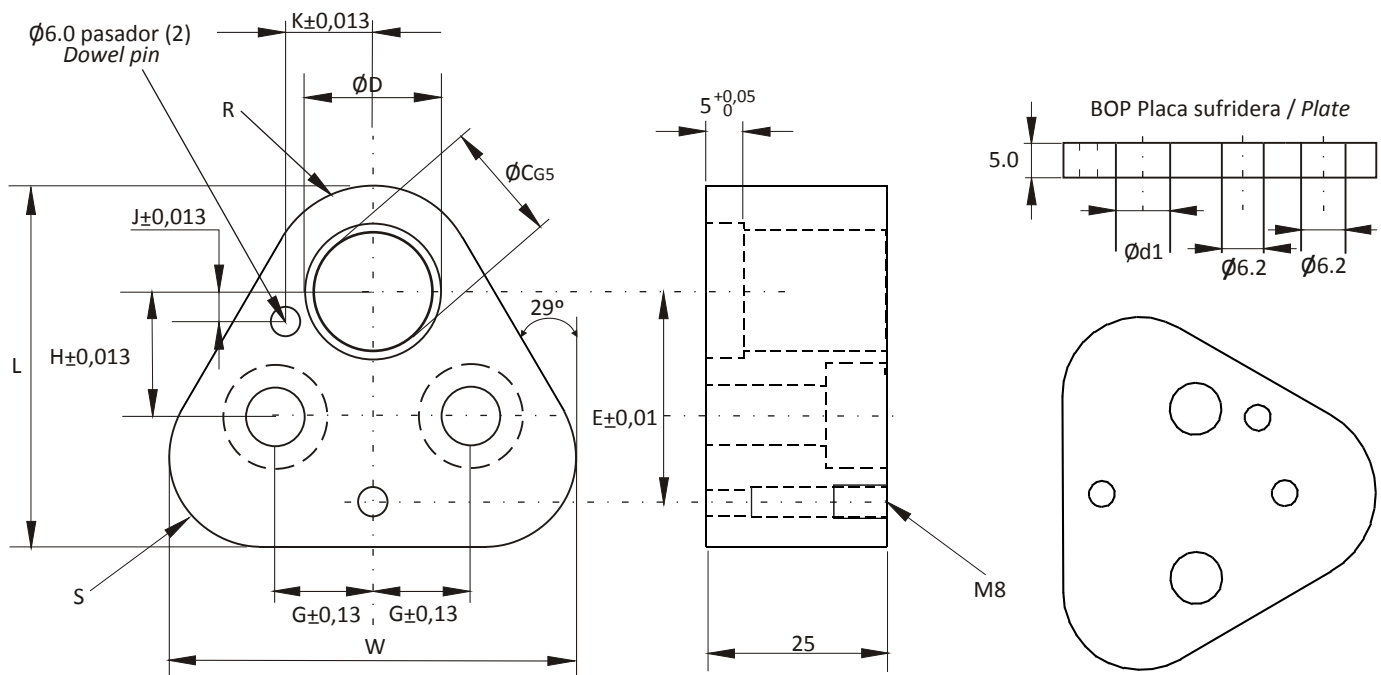

Ref.	C	L	W	D	G	H	R	S	E	K	J	Rosca Thread
HHR10	$10^{+0.009}_{-0}$	44,5	43,7	14,0	11,1	19,0	9,5	12,0	26,925	9,0	7,5	M8
HHR13	$13^{+0.011}_{-0}$	50,8	50,0	17,0	14,3	19,0	12,7	15,2	29,970	12,0	6,5	M8
HHR16	$16^{+0.011}_{-0}$	54,0	53,2	20,0	15,9	19,0	14,3	16,8	31,750	13,5	6,0	M8
HHR20	$20^{+0.013}_{-0}$	60,3	59,5	24,0	17,5	19,0	17,5	20,0	33,530	16,5	5,0	M10
HHR25	$25^{+0.013}_{-0}$	69,9	69,1	29,0	19,8	23,8	22,2	24,7	40,640	22,0	7,0	M12
HHR32	$32^{+0.016}_{-0}$	69,9	69,1	36,0	19,8	23,8	22,2	24,7	40,640	22,0	7,0	M12

FORMA DE PEDIDO / ORDER FORM : Ref.

Placa sufridera Plate	ϕ d1
BOP10	10
BOP13	10
BOP16	10
BOP20	12
BOP25	14
BOP32	14

FORMA DE PEDIDO / ORDER FORM : BOP Nr.

PORTA-PUNZONES CABEZA CILINDRICA CON POSICIONADOR " HHS "

SINGLE BALL LOCK CYLINDRICAL HEAD PUNCH RETAINERS " HHS "

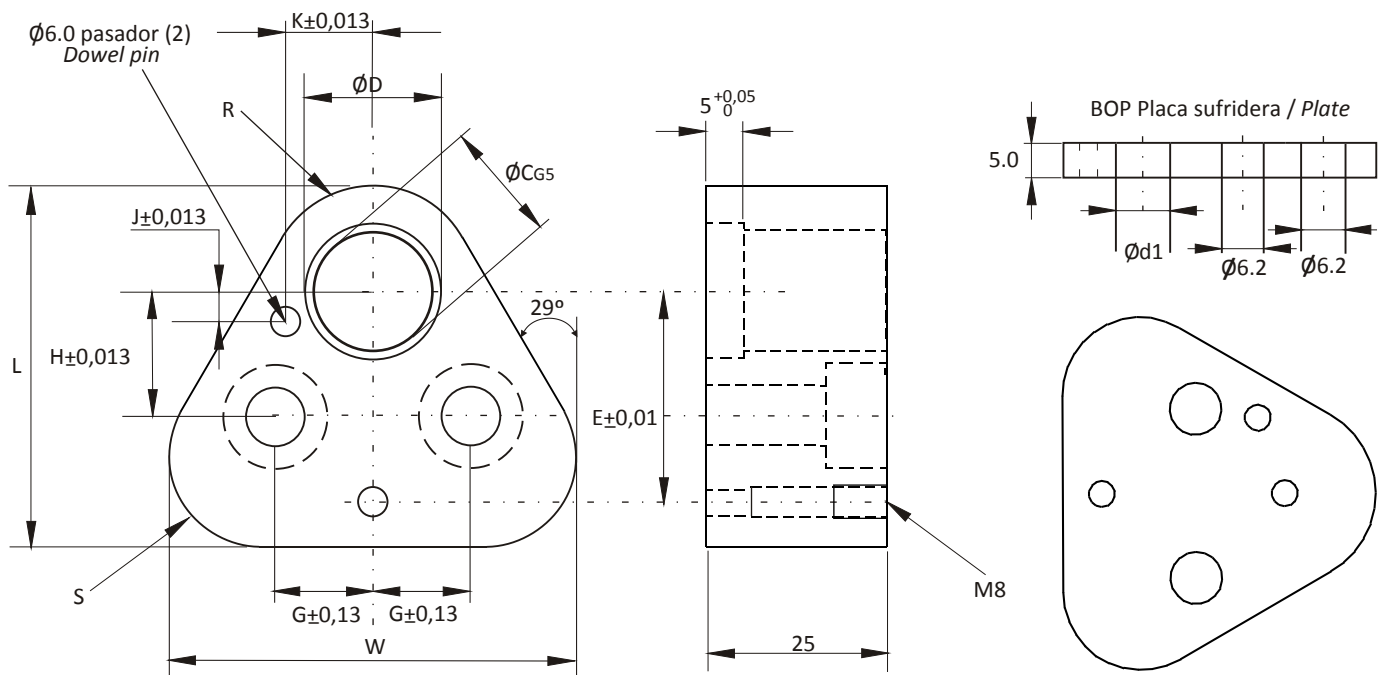

Ref.	C	A	B	D	G	H	R	S	E	K	J	Rosca Thread
HHS10	$10^{+0.009}_{-0}$	44,5	43,7	5,0	11,1	19,0	9,5	12,0	26,925	9,0	7,5	M8
HHS13	$13^{+0.011}_{-0}$	50,8	50,0	6,5	14,3	19,0	12,7	15,2	29,970	12,0	6,5	M8
HHS16	$16^{+0.011}_{-0}$	54,0	53,2	8,0	15,9	19,0	14,3	16,8	31,750	13,5	6,0	M8
HHS20	$20^{+0.013}_{-0}$	60,3	59,5	10,0	17,5	19,0	17,5	20,0	33,530	16,5	5,0	M10
HHS25	$25^{+0.013}_{-0}$	69,9	69,1	12,5	19,8	23,8	22,2	24,7	40,640	22,0	7,0	M12
HHS32	$32^{+0.016}_{-0}$	69,9	69,1	16,0	19,8	23,8	22,2	24,7	40,640	22,0	7,0	M12

FORMA DE PEDIDO / ORDER FORM : Ref.

Placa sufridera Plate	Ø d1
BOP10	10
BOP13	10
BOP16	10
BOP20	12
BOP25	14
BOP32	14

FORMA DE PEDIDO / ORDER FORM : BOP Nr.

MATRICES LAGRIMA CARGA LIGERA LIGHT DUTY BALL LOCK

TIPO TYPE: ECD

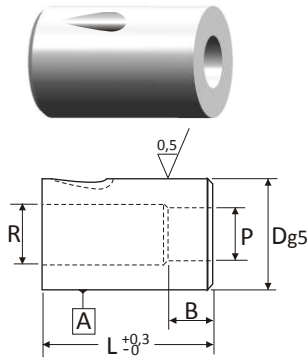

MATERIAL: Acero Steel: HSS
60-63 HRC.

ECDH

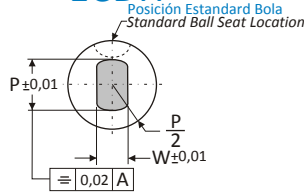

ECDX

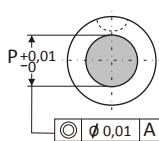

ECDK

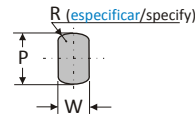

ECDO

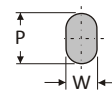

ECDJ

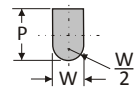

ECDR

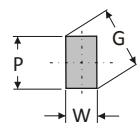

POSICION BOLA STANDARD

La posición standard de asiento bola es 90°. Otras posiciones alternativas pueden ser 0°, 180° o 270°

STANDARD BALL SEAT LOCATIONS

Standard Ball Seat Location is at 90°. Alternate locations of 0°, 180°, or 270°

POSICION ASIENTO BOLA PERSONALIZADA

Pueden especificarse posiciones personalizadas de asiento de bola, como BS y los grados contados en el sentido de las agujas del reloj, partiendo de 0°.

CUSTOM BALL SEAT LOCATIONS

Custom Ball Seat Locations can be specified as BS and degrees counter-clockwise from 0°.

POSICIONES DOBLE ASIENTOS BOLA

Un segundo asiento bola, puede ser requerido. Normalmente ubicado a 180° del primer asiento. Especificar SB y los grados deseados. Pueden estar localizados también a 90° del primer asiento.

DOUBLE BALL SEAT LOCATIONS

A second ball seat can be specified. Normally located 180° from the primary ball seat these are used to minimize sharpening of matrixes in notching operations by rotating 180°. Specify SB and degree desired. Can also be located 90° from primary ball seat.

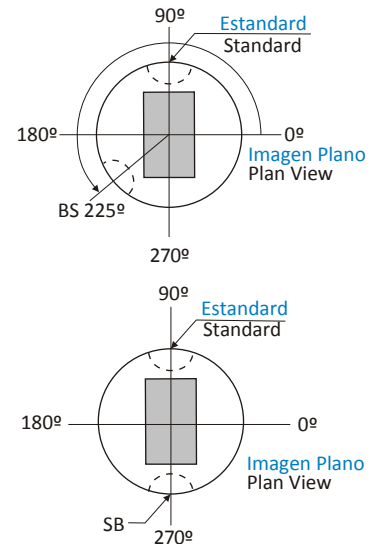

Forma de Pedido Order Form:

Especificar: Cantidad, Tipo, Diametro del Cuerpo y Codigo de Longitud, Diametro P, y Alteraciones Standard. Specify: Qty., Type, Body Dia. & Length Codes, P Dimensions and Standard Alterations.

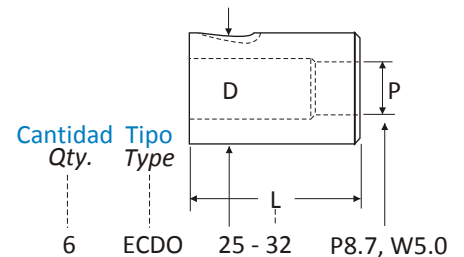

Diam. Cuerpo Body Dia. D	Min. B	Max. R	Tipo Type & D	Rango Range P	Tipo Type & D	Min. W	Max. P/G	L
								32
13	4	5,8	ECDX13	1.50- 5.00	ECD_13	1.20- 5.00	*	
16	5	8,0	ECDX16	3.20- 7.20	ECD_16	2.00- 7.20	*	
20	5	11,9	ECDX20	4.00- 11.00	ECD_20	2.40- 11.00	*	
25	6	16,0	ECDX25	8.00- 15.00	ECD_25	4.00- 15.00	*	
32	6	20,0	ECDX32	11.00- 19.00	ECD_32	4.80- 19.00	*	
38	8	27,0	ECDX38	16.50- 26.00	ECD_38	6.40- 26.00	*	